



# SCHWEIZER SERVICE BULLETIN

C1B-022.1  
21 Apr 2008

MANDATORY

MANDATORY

MANDATORY

**SUBJECT:** TAIL ROTOR DRIVE SHAFT SPLINED FITTINGS INSPECTION

**MODELS AFFECTED:** • All Model 269C-1 Helicopters.

**TIME OF COMPLIANCE:** Within the next 100 hours flight time or six months whichever comes first.

**REFERENCE:** 269C-1 Basic HMI, Revised: 30 Jan 2008.

**PREFACE:** • Excessive spline wear in the forward and aft tail rotor drive shaft splined fittings can lead to decoupling of the tail rotor drive shaft. A one time inspection is required within 100 hours flight time to check for excessive spline wear and to assure the drive shaft is properly lubricated. Follow-on periodic inspections of these components are required in accordance with HMI Appendix B, Table B-2.

- Failure to comply with this Service Bulletin can lead to loss of tail rotor thrust followed by possible loss of control of the helicopter.

**FAA APPROVAL:** The technical aspects of this Service Bulletin are FAA approved.

**PARTS REQUIRED:** Solvent Dry Cleaning (Stoddard) MIL-PRF-680, Type I,  
Varsol MIL-PRF-680, Type II, or equivalent

Grease Anderol 786, or Syn-Tech 3913G1

**PROCEDURE:**

- Remove tail rotor drive shaft from helicopter and disconnect from tail rotor transmission in accordance with pertinent steps of Basic HMI Section 10.
- Using cleaning solvent, remove all grease from spline cavities of tail rotor drive shaft forward and aft end fittings and main rotor transmission pinion splined drive sleeve and driven spline adapter of tail rotor transmission. Blow dry with clean compressed air.
- Inspect splines inside forward and aft drive shaft fittings for excessive wear, galling, spalling, distortion, corrosion, heat discoloration or lack of lubricant. Measure internal splines for wear using a 0.006 inch wire gage and straight edge as shown in Figure C1B-022-1. Measure all splines entirely around both fittings. If spline wear is beyond 0.006 inch limit, remove drive shaft from service.

NOTE

Drive shafts with spline wear beyond limits may be returned to the factory for fitting replacements. Contact Schweizer Aircraft Corp. Customer Support Department for details.

(█) Denotes portion of text added or revised

\*Supersedes DB-023, dated 30 Jan 2008

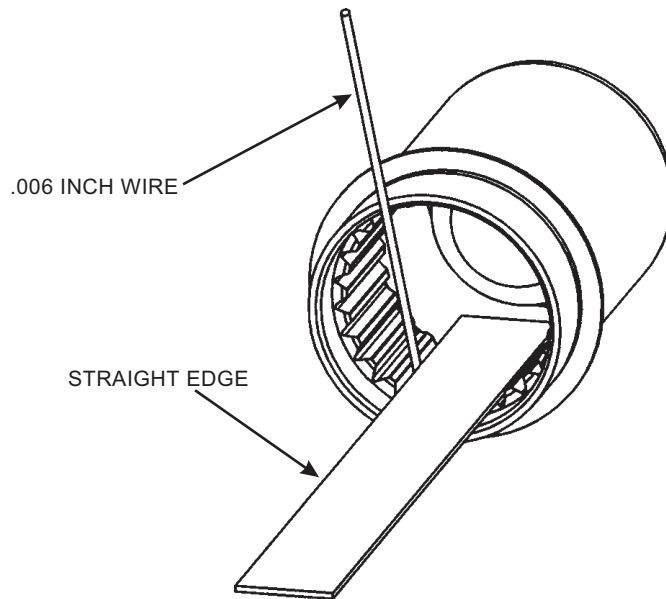

NOTE: The straight edge spline inspection is used in both the forward and aft drive shaft couplings.

Figure C1B-022-1. Drive Shaft Spline Wear Inspection

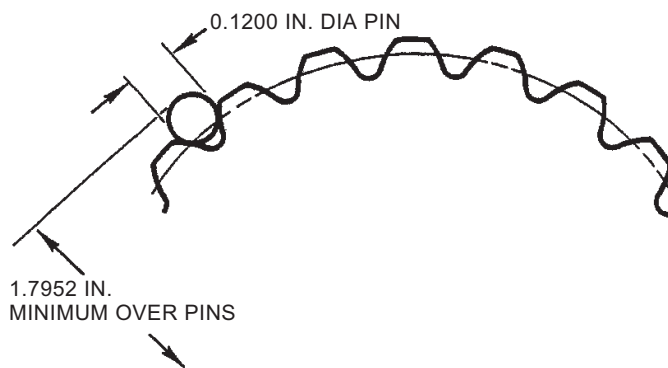

NOTE: The main transmission pinion drive spline sleeve and the tail rotor transmission driven spline have identical external spline dimensions. The over pin dimension inspection applies to both.

Figure C1B-022-2. Splined Drive Sleeve and Driven Spline Wear Inspection

- d. Inspect external splines of drive sleeve on main rotor transmission pinion and external splines of driven spline on tail rotor transmission input shaft for excessive wear, galling, spalling, distortion, corrosion, heat discoloration, or any defect that indicates inadequate spline engagement or lack of lubricant. Measure for excessive wear over two 0.1200 in. dia. gage pins placed 180° apart in external splines as shown in Figure C1B-022-2; minimum over pin dimension for both forward and aft adapters is 1.7952 inch. Measure all splines entirely around both adapters. Replace adapters if spline wear is out of limits.

NOTE

An HMI revision is in process to insure HMI over pin dimensions are consistent with the Service Bulletin.

- e. If tail rotor drive shaft is equipped with grease fittings, inspect grease fittings for security, presence of check balls inside fittings, and for proper operation and seating of check balls. Replace any fittings that are loose, are missing check balls, or are suspected of improper operation.
- f. Service drive shafts that are not equipped with grease fittings with either Anderol 786 or Syn-Tech 3913G1 grease (do not mix greases) to 1/8<sup>th</sup> inch above splines for full length of the splined cavities and apply 1/8 inch layer of grease to face of bumper plugs as shown in Figure C1B-022-3. (See HMI Section 10.)
- g. Assemble and install tail rotor drive shaft in helicopter in accordance with pertinent steps of Basic HMI Section 10. Assure drive shafts with grease fittings are lubricated with either Anderol 786 or Syn-Tech 3913G1 grease (do not mix greases). Lubricate aft fitting first and avoid aft preloading by alternately lubricating couplings at both ends.
- h. Record compliance with this Service Bulletin in the aircraft records.

WEIGHT AND BALANCE

Weight and Balance are not affected

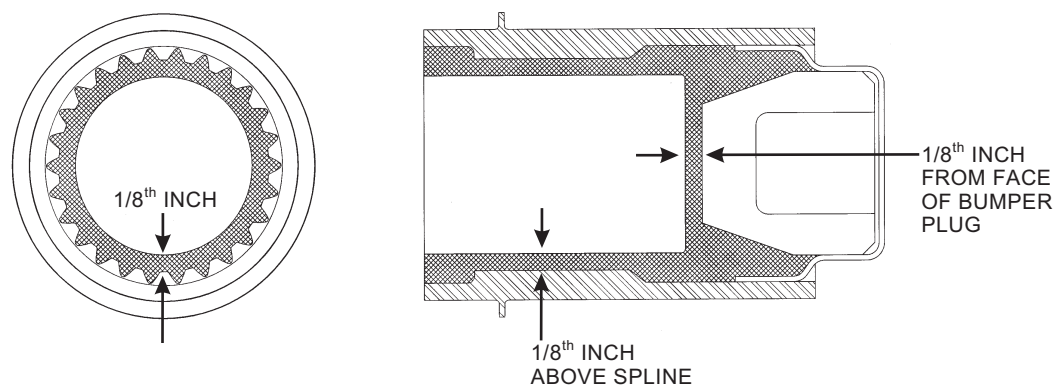

NOTE: This figure represents the design of both the forward and aft tail rotor drive shaft splined couplings. The dimension for each coupling's bumper plug position is different, however, each is lubricated to the same 1/8<sup>th</sup> inch grease depth specification. During operation, excess amounts of grease may escape past the O-ring seals of the retaining nuts. Figure C1B-022-4 provides drawings for the local fabrication of shop aids that can be used during greasing operation to assure the proper grease volume and distribution as shown.

Figure C1B-022-3. Lubrication Of Coupling Splines Without Grease Fittings

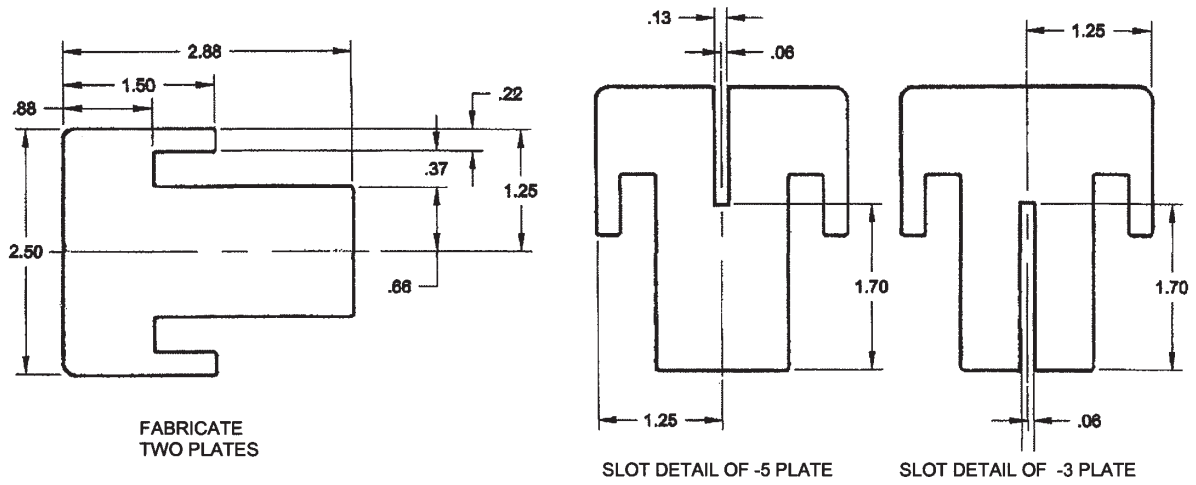

PLATE DETAILS FOR FORWARD SPLINED FITTING

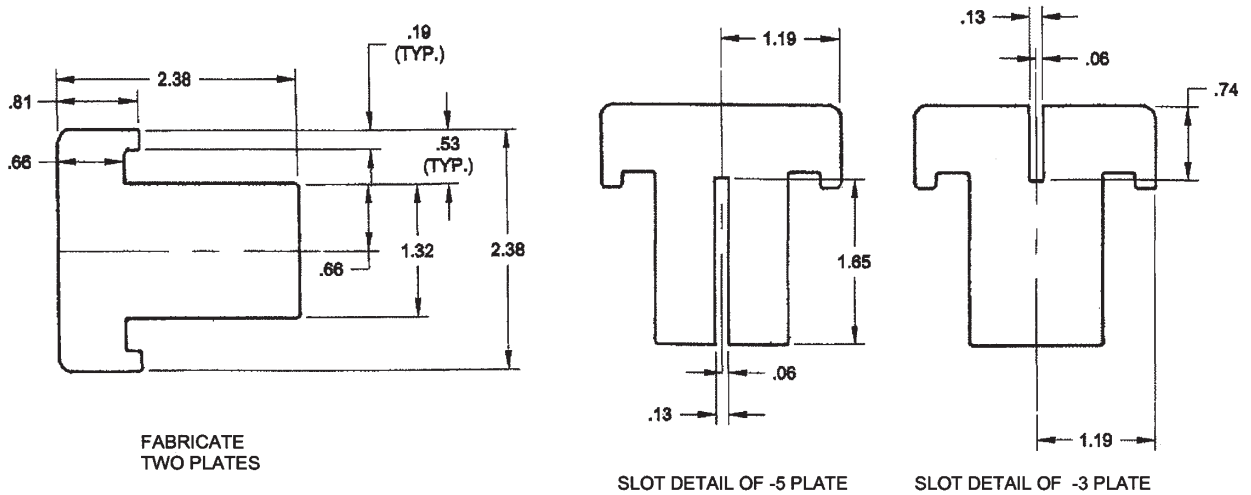
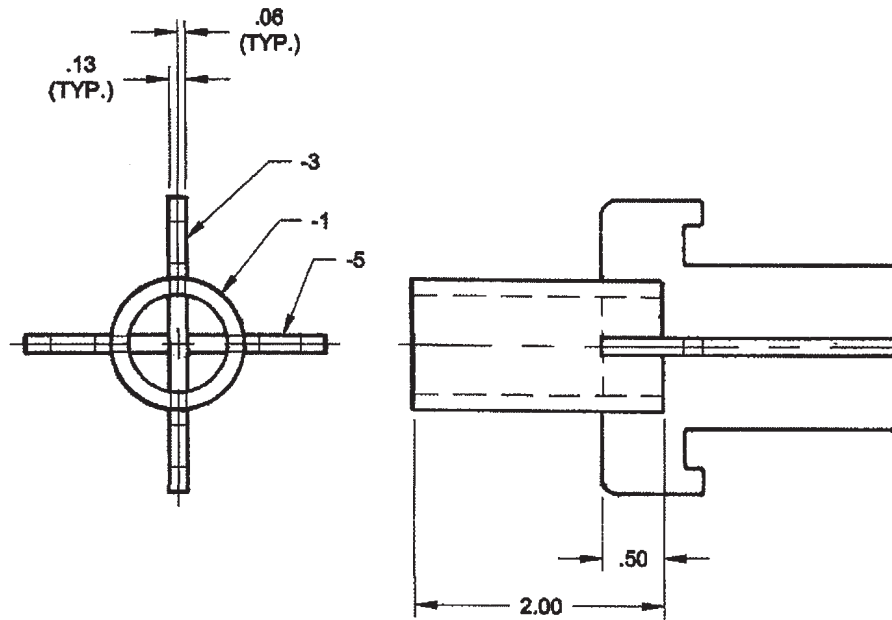

PLATE DETAILS FOR AFT SPLINED FITTING

NOTES:

1. SUGGESTED MATERIAL IS 1/8 INCH THICK POLYPROPYLENE PLASTIC SHEET AND 3/4 INCH PVC PIPE. ANY SUITABLE MATERIAL MAY BE USED.
2. FABRICATE - 1 PVC PIPE HANDLE AS SHOWN IN SHEET 2 WITH SLOTS 90° APART. SLOT WIDTHS ARE TO MATCH MATERIAL THICKNESS.
3. ASSEMBLE PARTS AS SHOWN IN SHEET 2 AND BOND ASSEMBLY TOGETHER USING APPROPRIATE ADHESIVE FOR PVC PIPE.

Figure C1B-022-4. Fabrication of Lubrication Tool Detail Parts (Sheet 1 of 2)



ASSEMBLY OF AFT SPLINED FITTING SHOWN

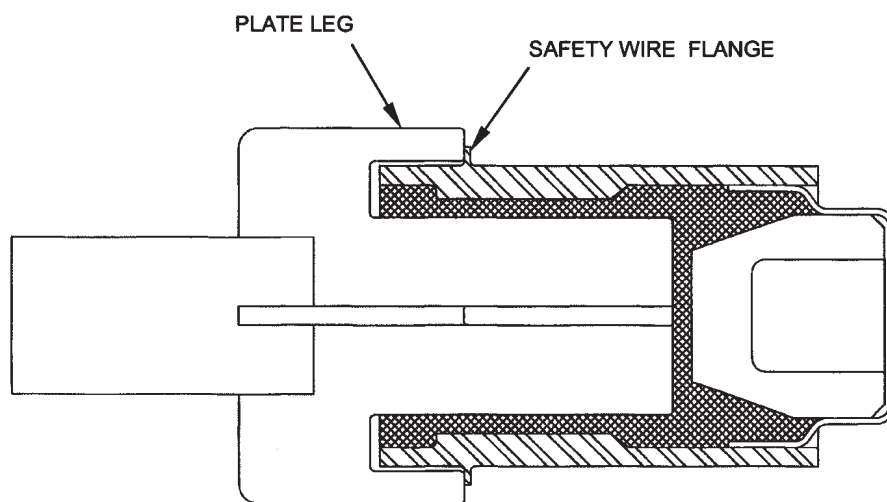

NOTES: USE OF GREASE TOOL FOR FORWARD SPLINE FITTING IS SHOWN. TO ADJUST GREASE VOLUME, INSERT TOOL UNTIL LEGS OF PLATES BOTTOM AGAINST SAFETY WIRE FLANGES ON EXTERIOR OF SPLINED FITTING. AFTER TOOL IS INSERTED, REMOVE EXCESS GREASE BY ROTATING TOOL A MINIMUM OF 180°. VERIFY GREASE COVERAGE AND DEPTH AS REQUIRED IN TEXT.

Figure C1B-022-4. Assembly and Use of Lubrication Tool (Sheet 2 of 2)