

269C

ALERT SERVICE BULLETIN



WARNING: THIS DOCUMENT, OR AN EMBODIMENT OF IT IN ANY MEDIA, DISCLOSES INFORMATION WHICH IS PROPRIETARY, IS THE PROPERTY OF SIKORSKY AIRCRAFT CORPORATION AND/OR ITS SUBSIDIARIES, IS AN UNPUBLISHED WORK PROTECTED UNDER APPLICABLE COPYRIGHT LAWS, AND IS DELIVERED ON THE EXPRESS CONDITION THAT IT IS NOT TO BE USED, DISCLOSED, REPRODUCED, IN WHOLE OR IN PART (INCLUDING REPRODUCTION AS A DERIVATIVE WORK), OR USED FOR MANUFACTURE FOR ANYONE OTHER THAN SIKORSKY AIRCRAFT CORPORATION AND/OR ITS SUBSIDIARIES WITHOUT ITS WRITTEN CONSENT, AND THAT NO RIGHT IS GRANTED TO DISCLOSE OR SO USE ANY INFORMATION CONTAINED HEREIN. ALL RIGHTS RESERVED. ANY ACT IN VIOLATION OF APPLICABLE LAW MAY RESULT IN CIVIL AND CRIMINAL PENALTIES.

EXPORT WARNING: THESE COMMODITIES, TECHNICAL DATA OR SOFTWARE ARE SUBJECT TO THE EXPORT CONTROL OF EITHER THE INTERNATIONAL TRAFFIC IN ARMS REGULATIONS (ITAR) OR THE EXPORT ADMINISTRATION REGULATIONS (EAR) AND CANNOT BE EXPORTED WITHOUT THE AUTHORIZATION OF EITHER THE DEPARTMENT OF STATE OR THE DEPARTMENT OF COMMERCE PRIOR TO EXPORT. EXPORT INCLUDES DISCLOSURE AND OR ACCESS TO COMMODITIES, TECHNICAL DATA OR SOFTWARE BY FOREIGN NATIONALS WHETHER LOCATED IN THE UNITED STATES OR ABROAD. THIS REQUIREMENT APPLIES EQUALLY TO FOREIGN NATIONAL EMPLOYEES OF U.S. COMPANIES AND THEIR FOREIGN SUBSIDIARIES.

B-298

Basic Issue ▪ January 04/12

SUBJECT: POWERTRAIN: One-Time Inspection of Belt Drive Idler Pulley Hardware for Presence and Security

Section 1. PLANNING INFORMATION

- A. **Effectivity** Model 269C helicopter with serial numbers S1926 through S1953.
- B. **Purpose** To perform a one-time inspection of Belt Drive Idler Pulley hardware for presence and security. An operational helicopter was found with its Belt Drive Idler Pulley nuts and washers not installed. A quality assurance investigation has narrowed suspect helicopter to serial numbers S1926 through S1953.
- C. **Description** The two bearing covers are removed to inspect nuts and tang washers for presence and secure installation and safety. If nuts and tang washers are properly installed, bearings are inspected for proper lubrication.
- D. **Compliance** Compliance is essential. The instructions outlined herein shall be accomplished within the next 100 flight hours or 60 days from the release date of this Alert Service Bulletin, whichever occurs first. If a 24-Month or 400-Hour periodic inspection to clean, inspect and repack the drive system bearings has been completed, no further action is required.
- E. **Approval** Inspection Item.

Section 1. PLANNING INFORMATION (Continued)

F. Manpower (Estimated)

<u>Task</u>	<u>No. of Men</u>	<u>No. of Hours</u>	<u>Man-Hours*</u>
1. Removal	1	2.0	2.0
2. Inspection	1	1.0	1.0
3. Reinstall and Record Compliance	1	2.5	2.5
Total Man-Hours			5.5

*Estimate does not include time required to prepare helicopter or return it to flight status.

G. Material

As required by HMI.

H. Tooling

As required by HMI.

I. Weight and Balance

Not affected.

J. Electrical Load Data

Not affected.

K. Software Load Data

Not changed.

L. References

- (1) CSP-C-10, S-300C Model 269C Helicopter, Basic Handbook of Maintenance Instructions (HMI) (Effective S/N 1809 and Subsequent), Dated 03 Oct 2003, Revised 21 May 2010, or later revision, Section 10.

M. Publications Affected

None.

N. Attachment

None.

Section 2. MATERIAL INFORMATION

A. Basis for Material Data

Per helicopter.

B. Bill of Material

As required by HMI.

C. Consumable Material

As required by HMI.

D. Tools Required

None.

Section 3. ACCOMPLISHMENT INSTRUCTIONS

A. Prepare helicopter for maintenance/inspection as follows:

- (1) Turn off all helicopter electrical power.
- (2) Gain access to the two pulley bearing covers (269A5581) in accordance with CSP-C-10, Section 10.
- (3) Remove six screws (NAS1096-2-7) that secure each cover (269A5581) to retainer (269A5580) (Figure 1).
- (4) Remove covers (269A5581).

B. Perform one-time inspection of belt drive idler pulley hardware as follows:

NOTE: Both sides of pulley are identical. The following inspection procedure is identical for each side of the pulley.

- (1) Inspect retaining nut (N-02) and tang washer (W-02) for presence and proper installation and safety in accordance with CSP-C-10, Section 10.
- (2) If retaining nut (N-02) and tang washer (W-02) are installed and secure, proceed to paragraph C. If retaining nut and/or tang washer are not installed, proceed as follows:
 - (a) Remove idler pulley in accordance with CSP-C-10, Section 10.
 - (b) Perform detailed inspection of adapters and bearings for serviceability in accordance with CSP-C-10, Section 10. Replace unserviceable or missing parts or hardware. Contact your Sikorsky Light Helicopter Service Center for replacement parts.
 - (c) Install serviceable pulley, nuts (N-02), tang washers (W-02) and covers (269A5582) in accordance with CSP-C-10, Section 10.

Section 4. ACCOMPLISHMENT INSTRUCTIONS (Continued)

(d) Proceed to paragraph C.

C. Completion procedures:

- (1) Verify proper lubrication of bearings in accordance with CSP-C-10, Section 10.
- (2) Install pulley bearing covers (269A5581). Secure with six screws (NAS1096-2-7) and washers. Refer to CSP-C-10, Section 10 for torque requirements.
- (3) Return helicopter to service.

D. Record of Compliance:

- (1) Make an appropriate helicopter logbook entry to show compliance with this ASB.
- (2) Complete attached ALERT SERVICE BULLETIN COMPLIANCE RECORD CARD and return it to Sikorsky Aircraft Corporation.

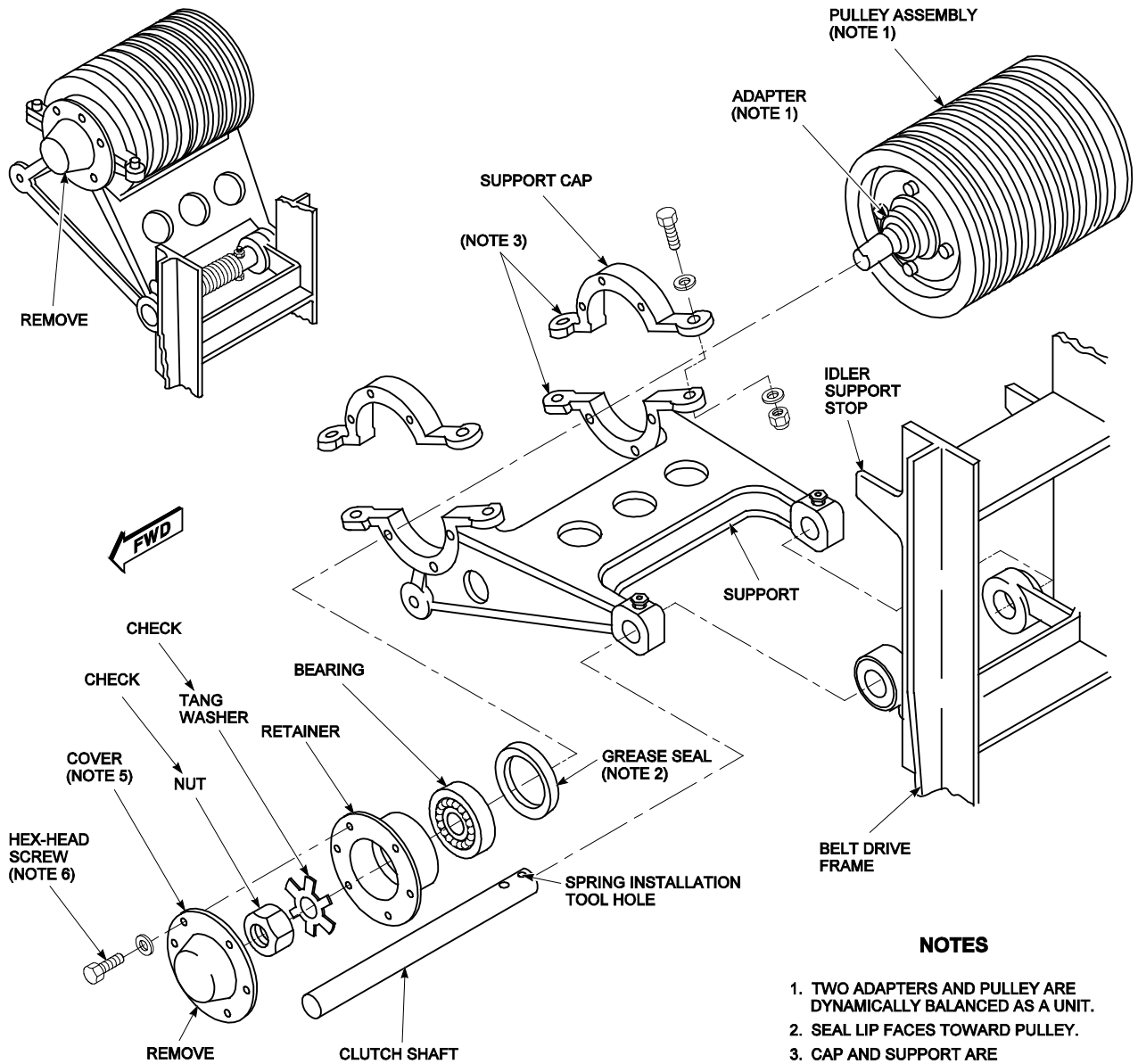

TD2630
SA

FIGURE 1. Adapter-Mounted Idler Pulley Clutch Installation (One-Piece Support)

ONE-TIME
INSPECTION

POWERTRAIN

(Fold over and tape closed)

SIKORSKY AIRCRAFT CORPORATION

FACSIMILE NUMBER (860) 998-7565

EMAIL ADDRESS: GPSIKSASProductSafet@utc.com

**ATTENTION: SAS PRODUCT SAFETY MANAGER
SIKORSKY AEROSPACE SERVICES**



IMPORTANT NOTICE

Upon COMPLIANCE with the attached SB, Sikorsky requests your cooperation in completing and returning this ENTIRE PAGE by MAIL.

Please fill in the requested information at the bottom of the page, so we may maintain proper records documenting the configuration of your aircraft. This information is useful when determining configuration and effectivity of issues affecting fielded aircraft.

This request is in keeping with our policy to assure that our customers receive the latest information applicable for the maintenance of your aircraft. Thank you.

SERVICE BULLETIN: _____ **B-298** _____ **Compliance Record Card**

TITLE: One-Time Inspection of Belt Drive Idler Pulley Hardware for Presence and
Security

OWNER/OPERATOR: _____

SUBMITTED BY: _____ **DATE:** _____

FOLLOWING SERIAL NUMBERS ARE NOT AFFECTED BY THIS SB

SB HAS BEEN COMPLIED WITH ON THE FOLLOWING SERIAL NUMBERS

(Fold Up to Arrows)



Postage
Required

SIKORSKY AIRCRAFT CORPORATION
P.O. BOX 9729
6900 MAIN STREET
STRATFORD, CONNECTICUT 06615-9129 U.S.A.
MAILSTOP: **S328A**
ATTENTION: SAS PRODUCT SAFETY MANAGER
SIKORSKY AEROSPACE SERVICES

Please complete the form on the reverse side and FAX to:
FACSIMILE NUMBER (860) 998-7565
Or scan and email to:
EMAIL ADDRESS: GPSIKSASProductSafet@utc.com
Or fold and return ENTIRE form to Sikorsky Aircraft Corporation