

SCHWEIZER AIRCRAFT CORP.

**Supplement to the Approved
Rotorcraft Flight Manual**

For

Schweizer 300C Model 269C Helicopter

**65.2 GALLON AUXILIARY FUEL SYSTEM INSTALLATION
(Part Number 269A8359-7)**

Date of Original Approval : February 27, 1997

Date of Rev. #1 Approval: Dec. 18, 2006

Approved By: *Michele Maurer*
for Anthony Socias,
Manager, NYACO, ANE-170

SCHWEIZER MODEL 269C HELICOPTER
CSP-C-1R

LOG OF PAGES

Page	Date	Page	Date
1	18 Dec 2006	11	27 Feb 1997
2	18 Dec 2006	12	18 Dec 2006
3	27 Feb 1997	13	18 Dec 2006
4	27 Feb 1997	14	18 Dec 2006
5	27 Feb 1997	15	27 Feb 1997
6	27 Feb 1997	16	18 Dec 2006
7	27 Feb 1997	17	18 Dec 2006
8	27 Feb 1997	18	27 Feb 1997
9	18 Dec 2006	19	27 Feb 1997
10	18 Dec 2006	20	27 Feb 1997

REVISION TABLE

Number Change	Date	Description
#1	18 Dec 2006	Weight & Balance Form format and misc. change.

SCHWEIZER MODEL 269C HELICOPTER
CSP-C-1R

INDEX

Paragraph Number	Title	Page No.
Section I	General	5
Section II	Limitations	6
Section III	Emergency and Malfunction Procedures	6
Section IV	Normal Procedures	7
Section V	Performance Data	7
Section VI	Weight & Balance Data	8
Section VII	Aircraft Handling, Servicing & Maintenance	19
Section VIII	Additional Operations & Performance Data	19

SCHWEIZER MODEL 269C HELICOPTER
CSP-C-1R

This page is left intentionally left blank.

SCHWEIZER MODEL 269C HELICOPTER
CSP-C-1R

SECTION I
General

This supplement must be carried in the applicable basic FAA approved 300C Model 269C Rotorcraft Flight Manual when the rotorcraft is equipped with a 65.2 gallon total capacity (63.0 gallon usable) fuel system. Except as modified by the flight manual supplement, operation in compliance with the basic approved Rotorcraft Flight Manual is mandatory.

The 65.2 gallon total capacity fuel system consists of the standard 30.0 gallon total capacity tank on the right side of the cabin interconnected to a 35.2 gallon total capacity auxiliary tank mounted behind the left side of the cabin. Both tanks feed through a T-fitting and fuel shut-off valve located below the auxiliary tank. A single flex line delivers fuel from the T-fitting to the electric boost pump.

SCHWEIZER MODEL 269C HELICOPTER
CSP-C-1R

SECTION II
Limitations

2-1. FUEL SYSTEM

TABLE 2-1. FUEL CAPACITY		
SYSTEM CAPACITY	QUANTITY	USABLE QUANTITY
MAIN + AUX	65.2 U.S. gallons	63.0 U.S. gallons

2-2. INSTRUMENT MARKINGS

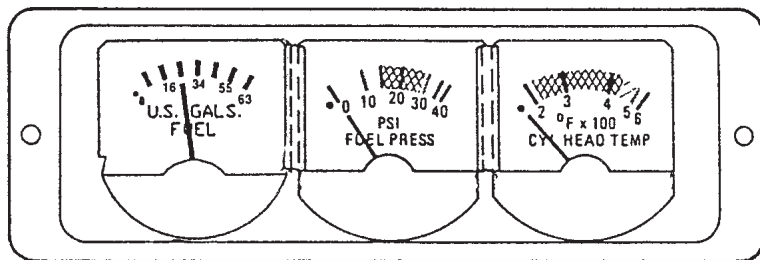

The above instrument cluster represents the “OPT” configuration available for aircraft equipped with an aux. fuel tank.

SECTION III
Emergency Procedures

Not Affected

SECTION IV
Normal Procedures

4-1 Pilot's Preflight Inspection

ENGINE - LEFT SIDE ③

Aux. fuel quantity level (if installed)	CHECK
Aux. fuel tank (if installed) cap seal for proper condition	CHECK
Fuel strainer, for debris or water (located on right side of aircraft on standard configuration)	DRAIN

SECTION V
Performance Data

Not affected

SCHWEIZER MODEL 269C HELICOPTER
CSP-C-1R

SECTION V
Weight and Balance Data

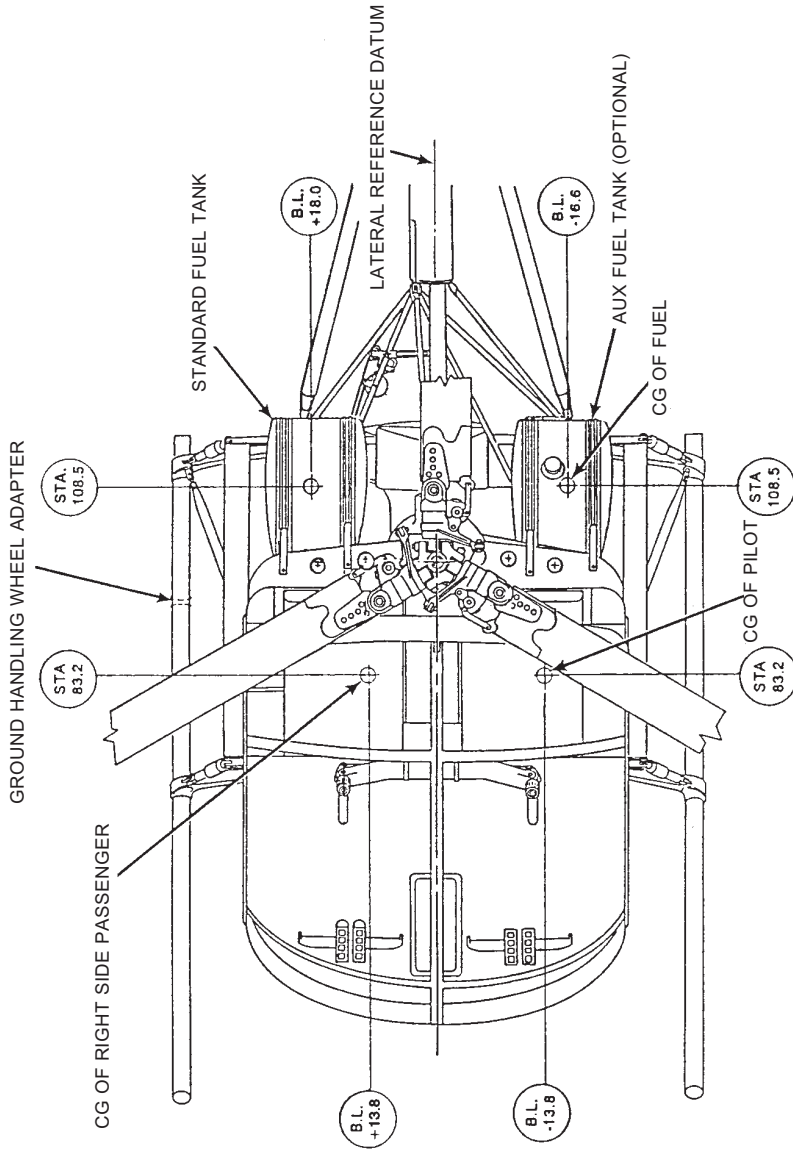

Figure 6-1. Balance Diagram

SCHWEIZER MODEL 269C HELICOPTER
CSP-C-1R

WEIGHT AND BALANCE WORKSHEET
Model 269C (300C)

HELICOPTER MODEL 269C		SERIAL NUMBER		REGISTRATION NUMBER			
DATE				WEIGHED BY			
WEIGHING POINT	SCALE READING (LB)	TARE (LB)	NET WEIGHT (LB)	LONGIT. ARM (IN)	LONGIT. MOMENT (IN-LBS)	LATERAL ARM (IN)	LATERAL MOMENT (IN-LBS)
LEFT MAIN	481.6	1.9	479.7	75.6	36265	-19.0	- 9114
RIGHT MAIN	499.5	1.9	497.6	75.6	37618	+19.0	+ 9454
AFT	148.0	2.9	145.1	271.4	39380	+0.6	+ 87
TOTAL (AS WEIGHED)	1129.1	6.7	1122.4	100.9	113263	+0.4	+ 427
A DISTANCE FROM STATION 100.0 TO MAIN WEIGHING POINTS IN INCHES		RIGHT HAND 24.4	LEFT HAND 24.4				
B AVERAGE MOMENT ARM FOR MAIN WEIGHING POINTS (100.0-A)		100.0 - 24.4 = 75.6					
C MOMENT ARM FOR AFT WEIGHING POINT IN INCHES		271.4					
OIL ABOARD		<input checked="" type="checkbox"/> YES	<input checked="" type="checkbox"/> NO				
MAIN GEAR BOX		<input checked="" type="checkbox"/> YES	<input type="checkbox"/> NO				
TAIL GEAR BOX		<input checked="" type="checkbox"/> YES	<input type="checkbox"/> NO				
FULL FUEL ABOARD		<input type="checkbox"/> YES	<input type="checkbox"/> NO				
REQUIRED EQUIPMENT MISSING AT TIME OF WEIGHING							
ITEM NUMBER	WEIGHT	LONGIT. ARM	LONGIT. MOMENT	LATERAL ARM	LATERAL MOMENT		
405 FLIGHT MANUAL	1.0	48.0	48	0	0		
UNUSABLE FUEL	13.2	108.5	1432	.7	9		
TOTAL	14.2	104.2	1480	.6	9		
OPTIONAL AND SURPLUS EQUIPMENT IN AIRCRAFT AT TIME OF WEIGHING							
ITEM NUMBER	WEIGHT	LONGIT. ARM	LONGIT. MOMENT	LATERAL ARM	LATERAL MOMENT		
TOTAL							

(CONTINUED ON BACK)

PAGE 1

Figure 6-2. Sample Weight and Balance Worksheet (sheet 1 of 2)

SCHWEIZER MODEL 269C HELICOPTER
CSP-C-1R

BASIC WEIGHT	WEIGHT (LB)	LONGIT. ARM (IN.)	LONGIT. MOMENT (IN.-LBS)	LATERAL ARM (IN.)	LATERAL MOMENT (IN.-LBS)
WEIGHT (AS WEIGHED)	1,122.4	100.9	113,263	.4	427
SURPLUS WEIGHT					
MISSING EQUIPMENT WEIGHT	14.2	104.2	1480	.6	9
TOTAL BASIC WEIGHT (DELIVERED)	1,137	100.9	114,743	.4	436
APPROVED FORWARD LIMIT 95 INCHES					
MOST FORWARD LOADING	WEIGHT (LBS)	LONGIT. ARM (IN.)	LONGIT. MOMENT (IN.-LBS)	LATERAL ARM (IN.)	LATERAL MOMENT (IN.-LBS)
BASIC WEIGHT	1,137	100.9	114,743	.4	436
PILOT	170.0	83.2	14,144	-13.8	-2346
FUEL EMPTY	0.0	108.5	0		
PASSENGER, CENTER	170.0	80.0	13,600	.75	128
PASSENGER, RIGHT	170.0	83.2	14,144	13.8	2346
TOTAL GROSS WEIGHT	1,647	95.1	156,631	.3	564
APPROVED FORWARD LIMIT 95 INCHES					
MOST AFT LOADING	WEIGHT (LB)	LONGIT. ARM (IN.)	LONGIT. MOMENT (IN.-LBS)	LATERAL ARM (IN.)	LATERAL MOMENT (IN.-LBS)
BASIC WEIGHT	1,137	100.9	114,743	.4	436
PILOT	170.0	83.2	14,144	-13.8	-2346
FUEL, 63 GAL. USABLE	378	108.5	41,013	-.68	-257
TOTAL GROSS WEIGHT	1,683	100.8	169,900	-1.3	-2167
APPROVED AFT LIMIT 101 INCHES					

6-2. Sample Weight and Balance Worksheet (sheet 2 of 2)

SCHWEIZER MODEL 269C HELICOPTER
CSP-C-1R

6-1. WEIGHT AND BALANCE DETERMINATION - PASSENGER CONFIGURATION

- • To determine that the gross weight and longitudinal center of gravity (fore and aft) for a given flight are within limits, proceed as follows:
- • Obtain the aircraft delivered weight and longitudinal moment from the Weight and Balance Record inserted in the back of this manual.
- • Determine weights and longitudinal moments of useful load items (see Figure 6-5).
- • Add the above items (see Example I).

EXAMPLE I

Items	Weight (lb)	Longitudinal Moment (in.-lb.)
Delivered Weight	1,137	114,743
Pilot - Left-Hand	170	14,144
Passenger - Right-Hand	170	14,144
Passenger - Center	170	13,600
1. Sub-Total Gross Weight	1,647	156,631
Fuel (63 Gal Usable)	378	41,013
2. Gross Weight	2,025	197,644

- Calculation of Longitudinal CG
- • CG (Zero Fuel Weight):

$$\frac{\text{Moment at Zero Fuel Weight}}{\text{Zero Fuel Weight}} = \frac{156,631}{1,647} = 95.1 \text{ in.}$$

SCHWEIZER MODEL 269C HELICOPTER
CSP-C-1R

- • CG (Gross Weight):

$$\frac{\text{Moment at Gross Weight}}{\text{Gross Weight}} = \frac{197,644}{2,025} = 97.6 \text{ in.}$$

Note: The CG's fall within the limits specified in Figure 6-3A; therefore, the loading meets the longitudinal CG requirements, for full fuel as well as zero fuel.

SCHWEIZER MODEL 269C HELICOPTER
CSP-C-1R

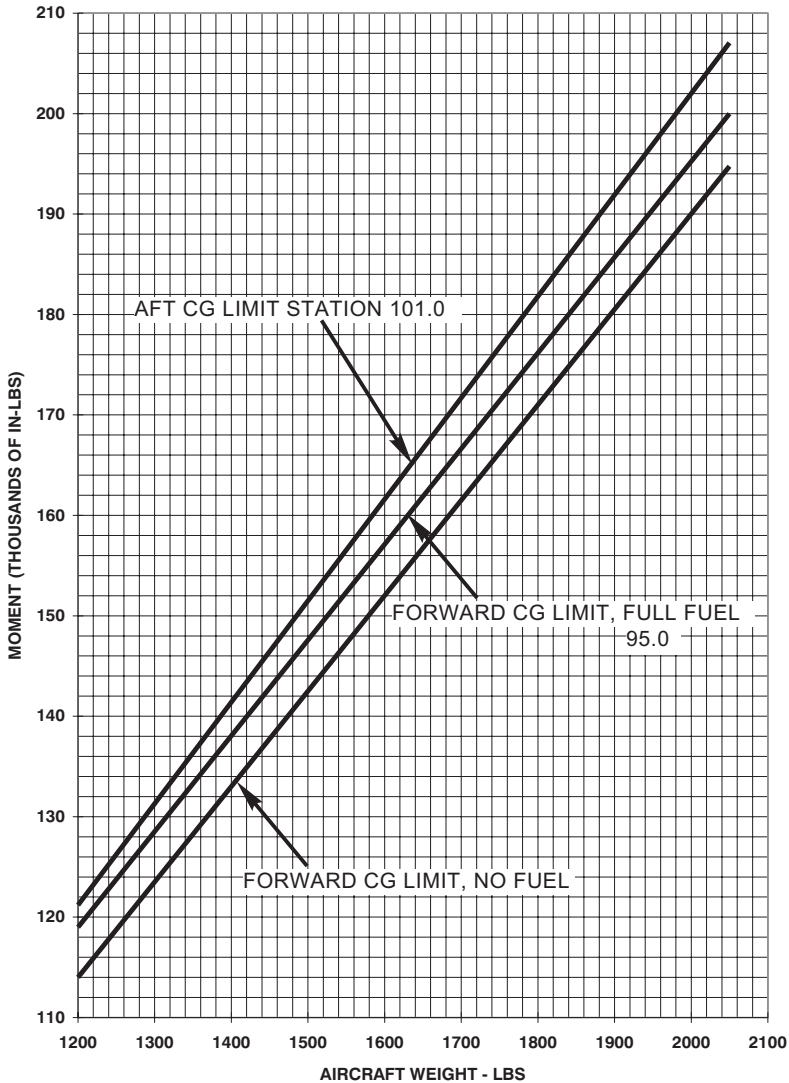

NOTE: This chart applies to the longitudinal center of gravity limits noted. CG limit changes or restrictions resulting from special kit installations require that CGs be determined by dividing total moment by total weight for both zero and full fuel conditions.

Figure 6-3A. Loading Chart - Longitudinal

**6-2. PERMISSIBLE LATERAL LOADINGS - PASSENGER
CONFIGURATION**

- For the safe operation of this helicopter, it must be flown within the established lateral as well as longitudinal center of gravity limits.

Note: Lateral center of gravity must be controlled.

- All combinations of passenger loadings are permissible if gross weight, longitudinal, and lateral center of gravity considerations permit.
- To determine that the gross weight and lateral center of gravity (left and right) are within limits for a given flight, proceed as follows:
 - Obtain the aircraft delivered weight and moment from the Weight and Balance Record inserted in this section (Fig. 6-3).
 - Determine weight and lateral moment of useful load items (see Figure 6-4).
 - Add the above items (see Example II).

SCHWEIZER MODEL 269C HELICOPTER
CSP-C-1R

EXAMPLE II

Items	Weight (lb)	Lateral Moment (in.-lb.)
Delivered Weight	1,137	+436
Pilot - Left-Hand	170	-2,346
Passenger - Right-Hand	170	+2,346
Passenger - Center	170	+128
1. Sub-Total Gross Weight	1,647	+564
Fuel - Full (63 Usable)	378	-257
2. Gross Weight	2,025	307

- • CG (Zero Fuel Weight):

$$\frac{\text{Moment at Zero Fuel Weight} \quad 564}{\text{Zero Fuel Weight} \quad 1,647} = \frac{\quad}{\quad} = +0.3 \text{ in.}$$

- • CG (Gross Weight):

$$\frac{\text{Moment at Gross Weight} \quad 307}{\text{Gross Weight} \quad 2,025} = \frac{\quad}{\quad} = +0.15 \text{ in.}$$

Note: The determined lateral CGs of +0.3 inch and +0.17 inch for longitudinal CGs of 95.1 inch and 97.6 inch respectively, fall within the established CG limits.

SCHWEIZER MODEL 269C HELICOPTER
CSP-C-1R

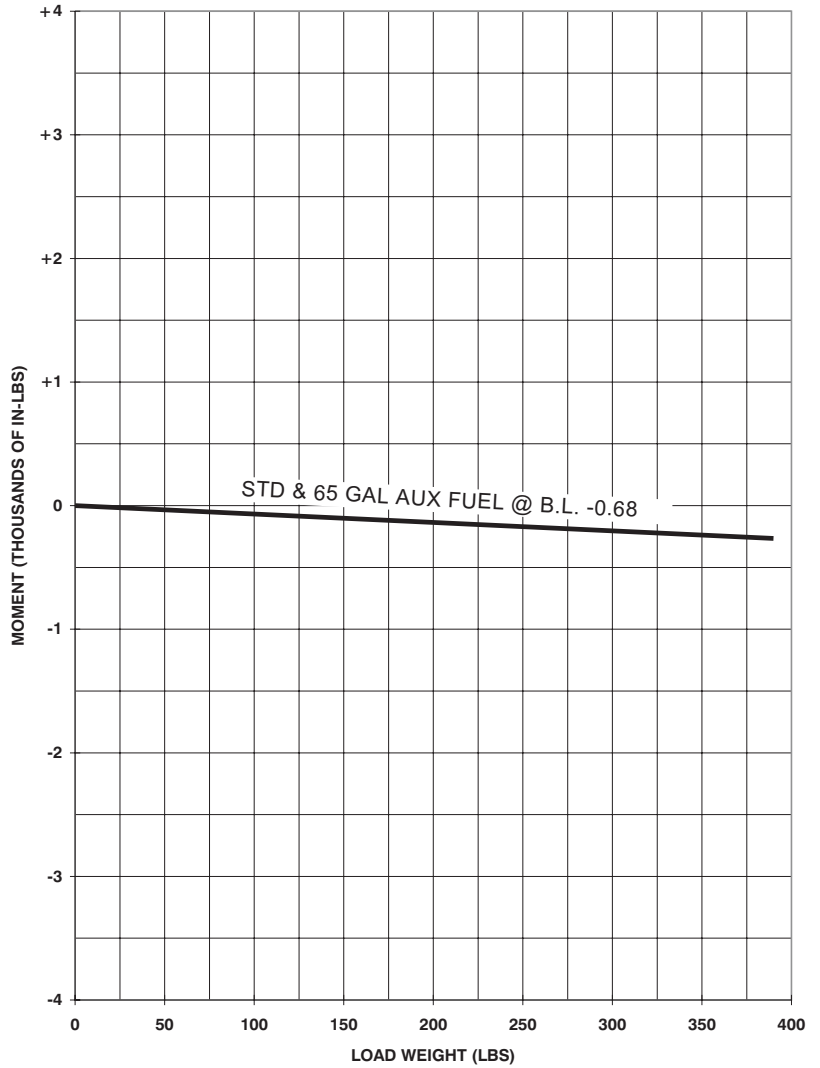

Figure 6-4. Weight and Moment Chart - Lateral

SCHWEIZER MODEL 269C HELICOPTER
CSP-C-1R

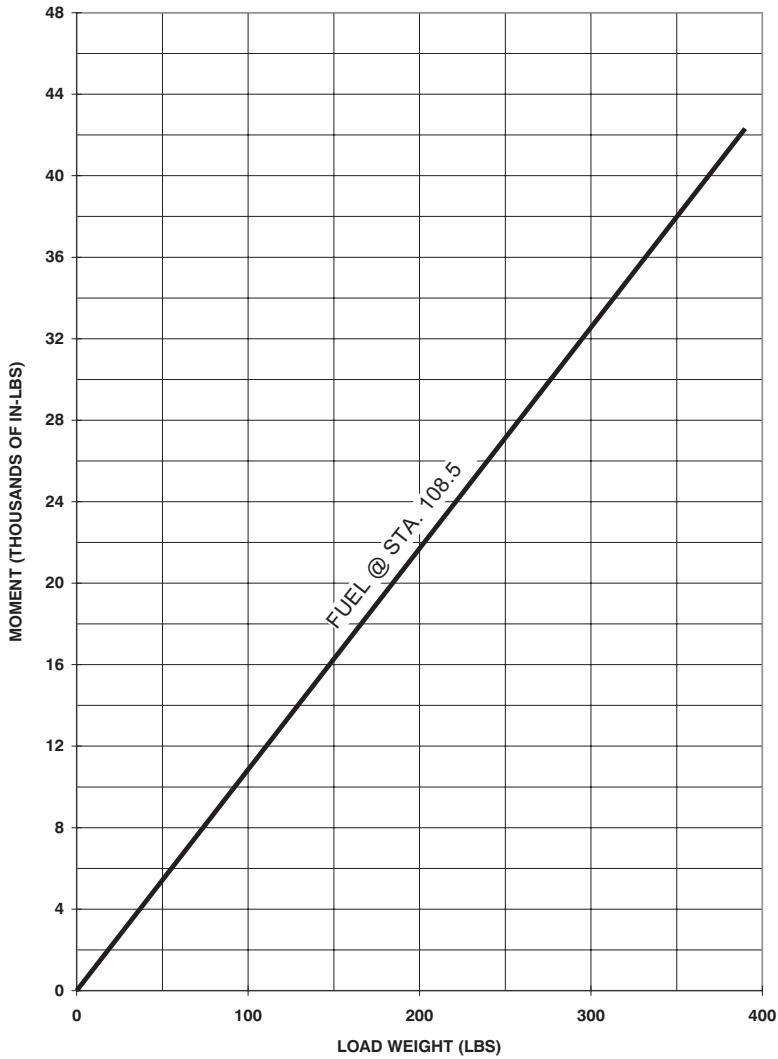

Figure 6-5. Weight and Moment Chart - Longitudinal

SECTION VII
Aircraft Handling, Servicing and Maintenance

7-1. FUEL SYSTEM

TABLE 7-1. FUEL CAPACITY		
SYSTEM CAPACITY	QUANTITY	USABLE QUANTITY
MAIN + AUX	65.2 U.S. gallons	63.0 U.S. gallons

SECTION VIII
Additional Operations and Performance Data
Not Affected

SCHWEIZER MODEL 269C HELICOPTER
CSP-C-1R

This page is intentionally left blank.