



SCHWEIZER SERVICE BULLETIN

B-236
4 Sep 1991

MANDATORY

MANDATORY

MANDATORY

SUBJECT: INSPECTION OF LOW TIP SPEED TAIL ROTOR SWASHPLATE BELLCRANK ASSEMBLY HOLE

MODELS AFFECTED: Model 269C Helicopters with Serial Numbers 1291 through 1432, inclusive, EXCEPT 1413 AND 1416

TIME OF COMPLIANCE: Shall be accomplished prior to the next flight after issue date of this Service Bulletin.

REFERENCES: BHMI - 269 Series Basic HMI (Reissued: 15 March 1982; Revision 1: 24 Aug 1990)

PREFACE: 269A6042 bellcrank assemblies have been manufactured with either a 3/16 (.19) inch or a 1/4 (.25) inch hole through the upper surface on the end which attaches to the tail rotor control rod assembly. Those assemblies manufactured with the 1/4 (.25) inch hole should have an installed bushing which reduces the hole size to 3/16 (.19) inch.

- A possibility exists that some helicopters were manufactured WITHOUT the installed bushing.
- A one-time inspection is required to determine if this hole is:
 - 3/16 (.19) inch (**CORRECT**)
 - 1/4 (.25) inch with installed bushing, 3/16 (.19) inch I.D. (**CORRECT**)
 - or 1/4 (.25) inch WITHOUT installed bushing (**INCORRECT**).
- Failure to comply with the requirements of this Service Bulletin at the time interval specified under TIME OF COMPLIANCE could result in excessive wear of the bellcrank and excessive play in the flight control system.

INSPECTION OF BELLCRANK ASSEMBLY HOLE

Procedure:

- a. Remove bolt attaching bellcrank assembly to tail rotor control rod (BHMI, Section 9). Determine assembly upper hole size (Figure B-236-1).
- b. If hole is 3/16 (.19) inch or 1/4 (.25) inch with installed bushing (I.D. 3/16 (.19) inch), reinstall bolt (BHMI, Section 9), ensuring slotted bushing is in place in LOWER hole. Proceed to step d. below.

- c. If hole is 1/4 (.25) inch WITHOUT installed bushing:
- (1) Do NOT rework bellcrank assembly. Return assembly to SAC.
 - (2) Replace bellcrank assembly with serviceable spare and reassemble after inspecting condition of tail rotor control rod (BHMI, Section 9).
 - (3) Contact SAC Product Support Department.
- d. Record compliance with this Service Bulletin in the aircraft records.

WEIGHT AND BALANCE

Weight and balance are not affected.

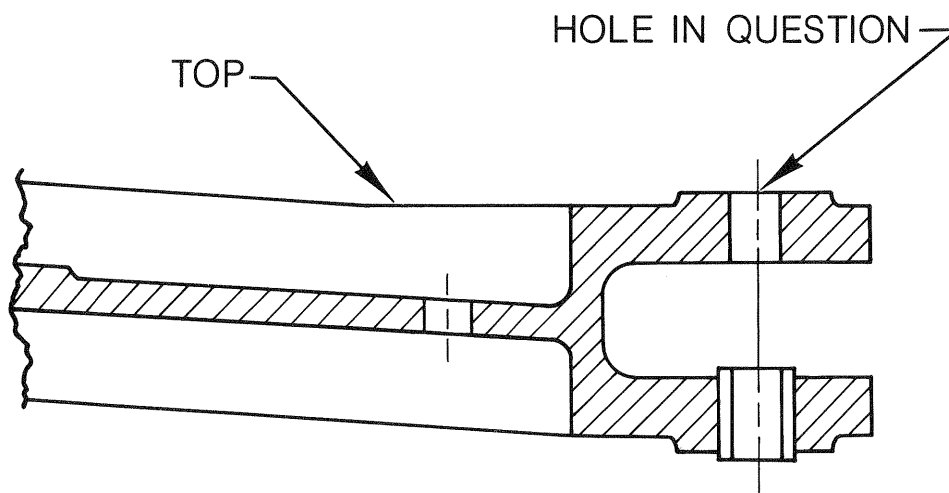

Figure B-236-1. 269A6042 Bellcrank Assembly Segment