



SCHWEIZER SERVICE BULLETIN

B-295.1*
28 Feb 2012

MANDATORY

MANDATORY

MANDATORY

SUBJECT: INSPECTION AND MODIFICATION OF TAILBOOM SUPPORT STRUT ADJUSTABLE DIAMETER BOLT

MODELS AFFECTED:

- Model 269C helicopter with serial No. 1846 and subsequent.
- All Model 269A, A-1, B, and C helicopters with Aft Cluster Fitting Modification Kit SA-269K-106 installed.

TIME OF COMPLIANCE: Part I: Prior to next flight for all helicopters.
Part II: Within next ten flight hours if not previously complied with.

REFERENCE:

- Model 269A, TH-55A, A-1, B & C Basic HMI
- Schweizer 300C, Model 269C Helicopter Basic HMI Effective Serial No. 1809 and subsequent.

PREFACE:

- Schweizer Aircraft received a report that a tailboom support strut adjustable diameter bolt came loose and departed the helicopter. An investigation concluded that the locknut holding the adjustable diameter bolt in place worked loose during flight.
- This service bulletin contains two parts:
 - Part I requires the operator to immediately verify that there is sufficient drag torque on the left-hand and right-hand locknuts, and that both locknuts are properly torqued.
 - Part II provides instructions to modify the ADB221-1A adjustable diameter bolt to allow the addition of a secondary safety mechanism. An ADB221-1B may be installed in lieu of the modified ADB221-1A.
- Both parts of this service bulletin must be complied with.

WARNING

FAILURE TO COMPLY WITH THIS SERVICE BULLETIN MAY LEAD TO LOSS OF CONTROL OF THE HELICOPTER AND SUBSEQUENT INJURY, DEATH AND/OR PROPERTY DAMAGE.

FAA APPROVAL: The technical aspects of this Service Bulletin are FAA approved.

PARTS REQUIRED: MS24665-132 Cotter Pin (Alternate MS24665-151) - 2 req'd
MS21043-3 Locknut - 2 req'd

(■) Denotes portion of text added or revised

* Supercedes B-295, dated 21 Dec 2010

PROCEDURE:

NOTE

There are two aft cluster fittings, each with an ADB221-1A adjustable diameter bolt. The following procedure is to be performed at each location. The 41 in-lbs. torque applied to the nut includes the required turning (drag) torque.

Due to the variations in drag torque measurements, the maximum drag torque value for a MS21043 locknut of 18 in-lbs. will be used per MIL-DTL-25027H.

Do not exceed the maximum final torque of 41 in-lbs. which is the desired torque (23 in-lbs.) plus the drag torque (18 in-lbs.).

PART I:

- a. See Figure B-295-1 and note locations of aft cluster fittings and adjustable diameter bolts.
- b. Loosen MS21043-3 locknut and verify turning (drag) torque of at least 2 in-lbs.
 1. If 2 in-lbs. or greater drag torque has been verified, re-torque locknut to 23 in-lbs. plus maximum drag torque of 18 in-lbs. for a final torque of 41 in-lbs.
 2. If drag torque is less than 2 in-lbs., replace with new MS21043-3 locknut and torque locknut to 23 in-lbs. plus a maximum drag torque of 18 in-lbs. for a final torque of 41 in-lbs.
- c. Record compliance with Part I of this service bulletin in the helicopter records.

PART II:

- a. Remove ADB221-1A adjustable diameter bolt from helicopter.
- b. Modify bolt as follows:
 1. Remove bolt from adjustable assembly and retain all parts.
 2. Secure bolt in drill vise.
 3. Using a drill press, drill 0.070-0.080-inch diameter hole through threaded portion of bolt, centered 0.083-0.093-inch from end of bolt as shown in Figure B-295-1.
 4. Chase threads of bolt to remove any burrs.

CAUTION

Assembly, orientation and installation of the ADB221-1A adjustable diameter bolt is critical. Assure it is assembled in the correct order and installed in accordance with the Basic HMI, Section II, Figure 11-2.

- c. Reassemble washer and bushings onto bolt in accordance with Basic HMI, Section 11.
- d. Install adjustable diameter bolt (Basic HMI, Section 11).
- e. Install new MS21043-3 locknut on bolt and torque locknut to 23 in-lbs. plus a maximum drag torque of 18 in-lbs. for a final torque of 41 in-lbs.
- f. Install MS24665-132 or MS24665-151 cotter pin on adjustable diameter bolt.
- g. Record compliance with Part II of this service bulletin in the helicopter records.

WEIGHT AND BALANCE

Weight and Balance are not affected.

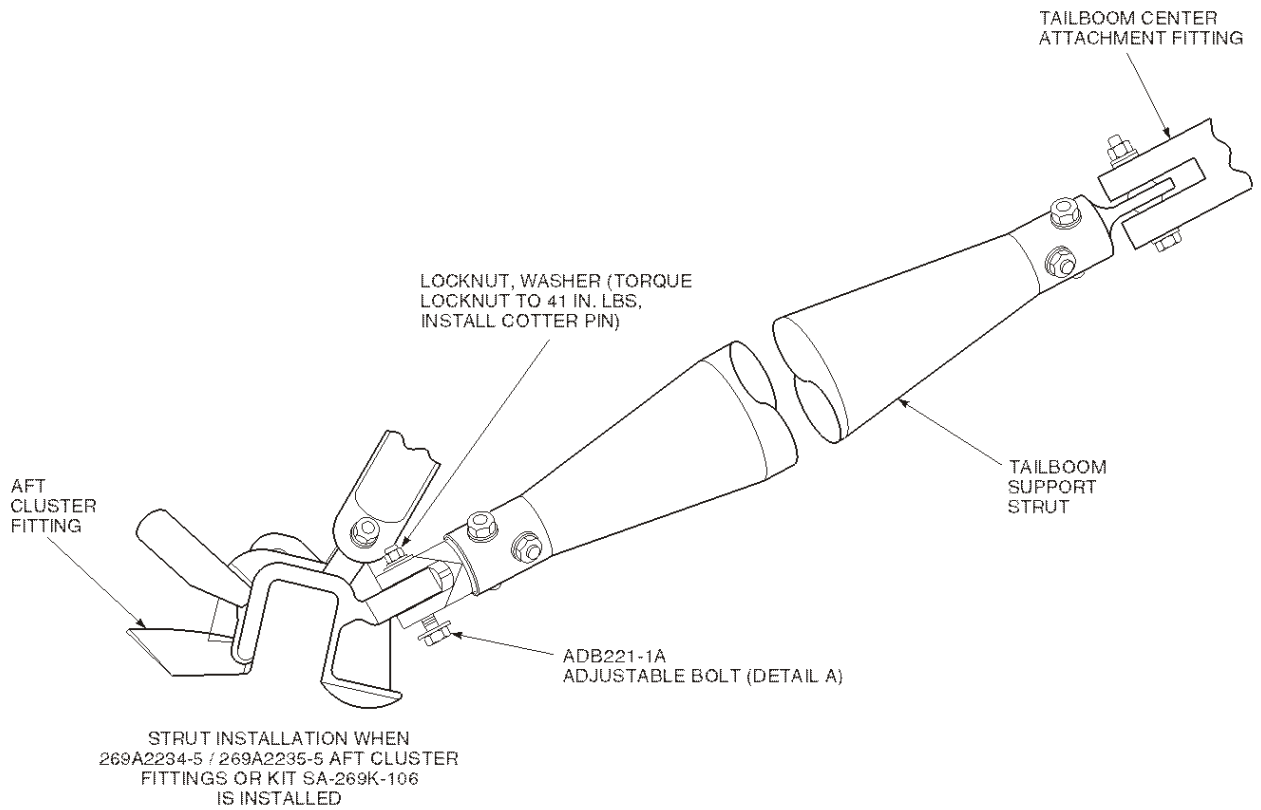

TYPICAL LEFT SIDE AND RIGHT SIDE

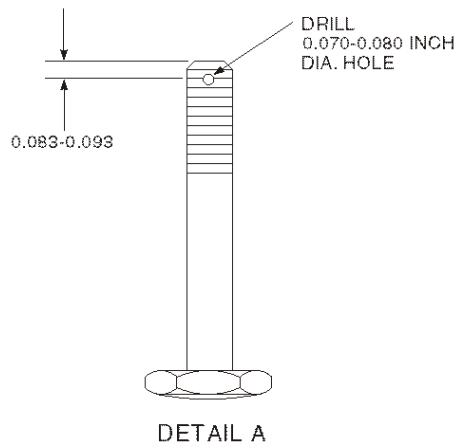

Figure B-295-1. Tailboom Support Strut Adjustable Diameter Bolt Inspection and Modification