

**SCHWEIZER
SERVICE INFORMATION
LETTER**

LETTER NO. L-107
DATE 10 December 1979
PAGE 1 OF 2

TO—All owners and operators of Hughes Helicopters

SUBJECT: NEW COMFORT CLIPS FOR SAM BROWNE SEAT BELT AND
SHOULDER HARNESS ASSEMBLIES

MODELS AFFECTED: Model 269C Helicopters equipped with PN 269A4345
Sam Browne seat belt assemblies, Serial No. 0530
thru 0960

Reference

269 Series - Basic HMI, Issued 1 April 1973; Revision No. 5, 1 February 1978

A new comfort clip (PN E3403) designed to maintain proper strap tension, and relieve excessive pressure of the inertia reel shoulder harness on the pilot or passenger during flight, is now available for the above affected helicopters equipped with Sam Browne seat belt assemblies.

After each seat belt and shoulder harness assembly is fastened and adjusted for individual comfort and safety, the comfort clip is moved from its original position next to the buckle and relocated by sliding up on the harness strap as close as possible to the inertia reel (see Figure 1). The clip prevents any further retraction of the strap into the inertia reel, thus keeping a constant yet comfortable tension of the harness strap against the pilot or passenger. After each flight, the comfort clip is to be returned to its original location on the harness strap next to the buckle.

The comfort clips may be obtained without charge by contacting your authorized HH Service Center. Please order by helicopter Serial Number; and specify one PN E3403 comfort clip and one PN 369D2402-5 decal for each seat belt assembly installed on the helicopter. Hughes Service Centers may procure the comfort clips by contacting Warranty and Repair.

A handwritten signature in dark ink, appearing to read 'Edward Koch'.

Edward Koch, Manager
Customer Service Department
Hughes Helicopters

Customer Service Department - Hughes Helicopters - Culver City, California

SCHWEIZER AIRCRAFT CORP. P.O. Box 147 Elmira, NY 14902

LETTER NO. L-107
 DATE: 10 December 1979
 PAGE: 2 of 2

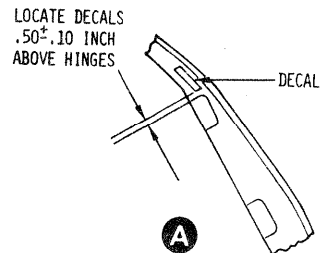
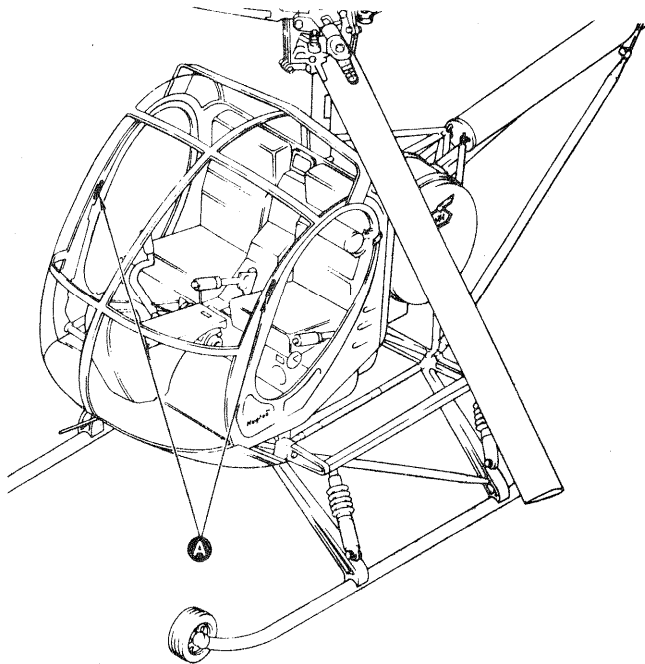

VIEW LOOKING OUTBOARD
 FROM ϕ OF SHIP
 TO LH SIDE

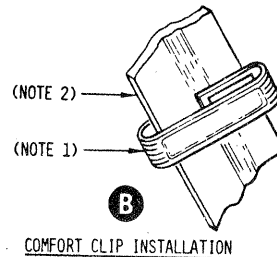

TO APPLY DECAL:

1. CLEAN DOOR FRAME AREA WHERE DECALS ARE TO BE APPLIED. DECALS WILL NOT ADHERE TO A GREASY OR SOAPY FILM.
2. MARK LOCATION OF DECAL PER THE ILLUSTRATION. REPEAT ON THE OTHER DOOR FRAME.
3. PEEL BACKING OFF DECAL AND POSITION. USE A CLOTH TO SQUEEZE ALL BUBBLES FROM UNDER THE DECAL, WORKING FROM THE CENTER OUTWARD. REPEAT ON THE OTHER DOOR FRAME.

TO INSTALL COMFORT CLIP:

1. PRY OPEN SLOT ON UNDERSIDE OF CLIP.
2. INSERT HARNESS STRAP IN SLOT.

AFTER SEAT BELT AND SHOULDER HARNESS ASSEMBLY IS FASTENED AND ADJUSTED FOR INDIVIDUAL COMFORT AND SAFETY:

3. SLIDE COMFORT CLIP UP ON HARNESS STRAP AND POSITION AS CLOSE AS POSSIBLE NEXT TO INERTIA REEL.

AFTER EACH FLIGHT:

4. REPOSITION COMFORT CLIP ON HARNESS STRAP AT ORIGINAL POSITION NEXT TO BUCKLE.

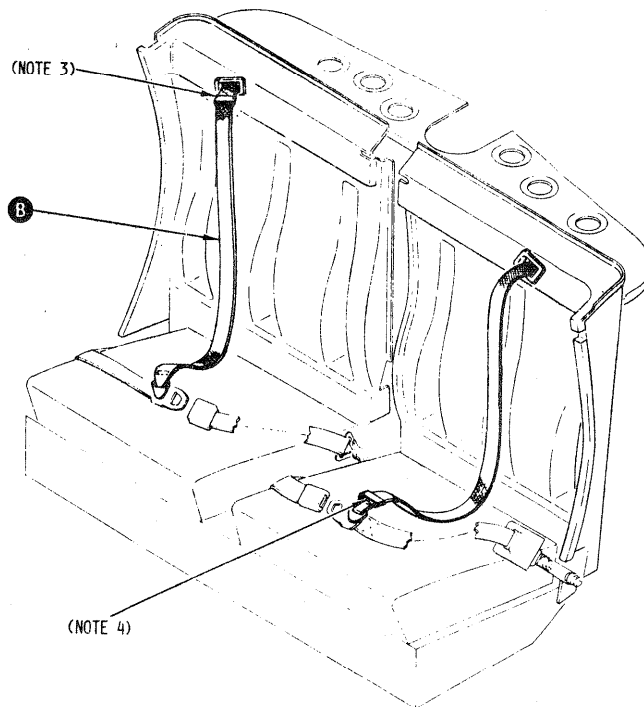

Figure 1. Comfort Clip Decal Application
 And Clip Installation Instructions