



HUGHES
SERVICE INFORMATION
LETTER

TRAINING

LETTER NO. L-22
DATE August 22, 1967
PAGE 1 OF 7

TO—All owners and operators of Hughes Helicopters

SUBJECT: INTERIM REVISION - HANDBOOK OF MAINTENANCE INSTRUCTIONS RE: INSTALLATION PITCH CONTROL ROD, INSPECTION PITCH BEARING CASES, MAIN ROTOR SWASHPLATE ASSEMBLY AND SWASHPLATE SCISSORS LINK.

MODELS AFFECTED: All 269 Series Helicopters

Reference

269A/A-1 Handbook of Maintenance Instructions
TH55A HMI Addendum
269B Handbook of Maintenance Instructions

The information given in this Service Information Letter lists instructions to assure proper operation of P/N 1338-3 main rotor pitch control rod. Also included are inspection procedures and wear tolerances for the main rotor blade pitch bearing case, main rotor swashplate assembly and swashplate scissors link. This data is to be considered a part of the HMI until formal incorporation is accomplished at the next revision cycle.

269A/A-1 Handbook of Maintenance Instructions

Pg. 4-17, Para. 4-35, INSPECTION - MAIN ROTOR PITCH BEARING ASSEMBLY, following step e.

- ADD: f. Inspect lugs of pitch bearing case for evidence of wear resulting from interference with bearing at top of pitch control rod; rework grooves exceeding 0.003" depth on inner faces of lugs; touch up after rework with zinc chromate primer. (See Figure 1)

LETTER NO. L-22
DATE August 22, 1967
PAGE 2 OF 7

Pg. 4-18, Para. 4-38. INSTALLATION - MAIN ROTOR BLADE PITCH BEARING ASSEMBLY, following step f.

ADD:

NOTE

To assure that pitch control rod is positioned correctly determine that top of control rod with 5050-34 bearing (RH thread) is installed at the pitch bearing case, and lower end of the control rod with 5050-41 or 5050-49 bearing (LH thread) is installed at the swashplate. To check proper installation, note that safetywire hole in control rod is closer to the top of the rod.

CAUTION

Inspect lugs of pitch bearing case for evidence of interference with bearing at top of pitch control rod, resulting from (a) improper installation of pitch control rod or (b) adverse tolerances between top bearing and lugs of pitch bearing case.

If interference between top bearing and pitch arm lugs is found:

1. With existing control rod not properly positioned, remove and install control rod as noted above.
2. With existing control rod correctly positioned, remove and replace top bearing with 5050-34 bearing.

Pg. 4-22, Para. 4-49. INSPECTION - MAIN ROTOR SWASHPLATE ASSEMBLY AND BEARING SLEEVE ASSEMBLY, following step e.

DELETE: Existing steps f. and g.

ADD: New steps f., g., and h.:

f. Inspect upper swashplate for condition and evidence of wear on inner faces of lugs; rework grooves exceeding 0.003" depth on inner faces of lugs; touch up after rework with zinc chromate primer. (See Figure 2)

g. Inspect bushings on arms of upper and lower swashplate scissors. Maximum allowable inside diameter of 1312 or 1313 bushing is 0.383 inch; maximum allowable axial play (due to wear on flanges of 1312 or 1313 bushings and 1323 bushings) is 0.040 inch. (See Detail B, Figure 3) After reassembly, use feeler gage for minimum 0.001 inch clearance between bushing flanges to provide free oscillating movement of scissors.

NOTE

The 1309 scissors may be fitted with 1312 bushings when replacing 1313 bushings due to wear. Zerk fittings may be removed and holes plugged with epoxy cement.

h. Inspect dust boots for condition, hard oxidation spots, and cracking. Replace dust boots as required.

269B Handbook of Maintenance Instructions

Pg. 4-16, Para. 4-30. INSPECTION - MAIN ROTOR PITCH BEARING ASSEMBLY, following step e.

ADD: f. Inspect lugs of pitch bearing case for evidence of wear resulting from interference with bearing at top of pitch control rod; rework grooves exceeding 0.003" depth on inner faces of lugs; touch up after rework with zinc chromate primer. (See Figure 1)

Pg. 4-17, Para. 4-32. INSTALLATION - MAIN ROTOR BLADE PITCH BEARING ASSEMBLY, following step f.

ADD:

NOTE

To assure that pitch control rod is positioned correctly, determine that top of control rod with 5050-34 bearing (RH thread) is installed at the pitch bearing case, and lower end of the control rod with 5050-41 or 5050-49 bearing (LH thread) is installed at the swashplate. To check proper installation, note that safetywire hole in control rod is closer to the top of the rod.

CAUTION

Inspect lugs of pitch bearing case for evidence of interference with bearing at top of pitch control rod, resulting from (a) improper installation of pitch control rod or (b) adverse tolerances between top bearing and lugs of pitch bearing case.

If interference between top bearing and pitch arm lugs is found:

1. With existing control rod not properly positioned, remove and install control rod as noted above.
2. With existing control rod correctly positioned, remove and replace top bearing with 5050-34 bearing.

Pg. 4-21, Para. 4-43. INSPECTION - MAIN ROTOR SWASHPLATE ASSEMBLY AND BEARING SLEEVE ASSEMBLY, following step e.

DELETE: Existing steps f. and g.

ADD: New steps f., g. and h.

f. Inspect upper swashplate for condition and evidence of wear on inner faces of lugs; rework grooves exceeding 0.003" depth on inner faces of lugs; touch up after rework with zinc chromate primer. (See Figure 2)

g. Inspect bushings on arms of upper and lower swashplate scissors. Maximum allowable inside diameter of 1312 or 1313 bushing is 0.383 inch; maximum allowable axial play (due to wear on flanges of 1312 or 1313 bushings and 1323 bushings) is 0.040 inch. (See Detail B, Figure 3) After reassembly, use feeler gage for minimum 0.001 inch clearance between bushing flanges to provide free oscillating movement of scissors.

NOTE

The 1309 scissors may be fitted with 1312 bushings when replacing 1313 bushings due to wear. Zerk fittings may be removed and holes plugged with epoxy cement.

h. Inspect dust boots for condition, hard oxidation spots, and cracking. Replace dust boots as required.

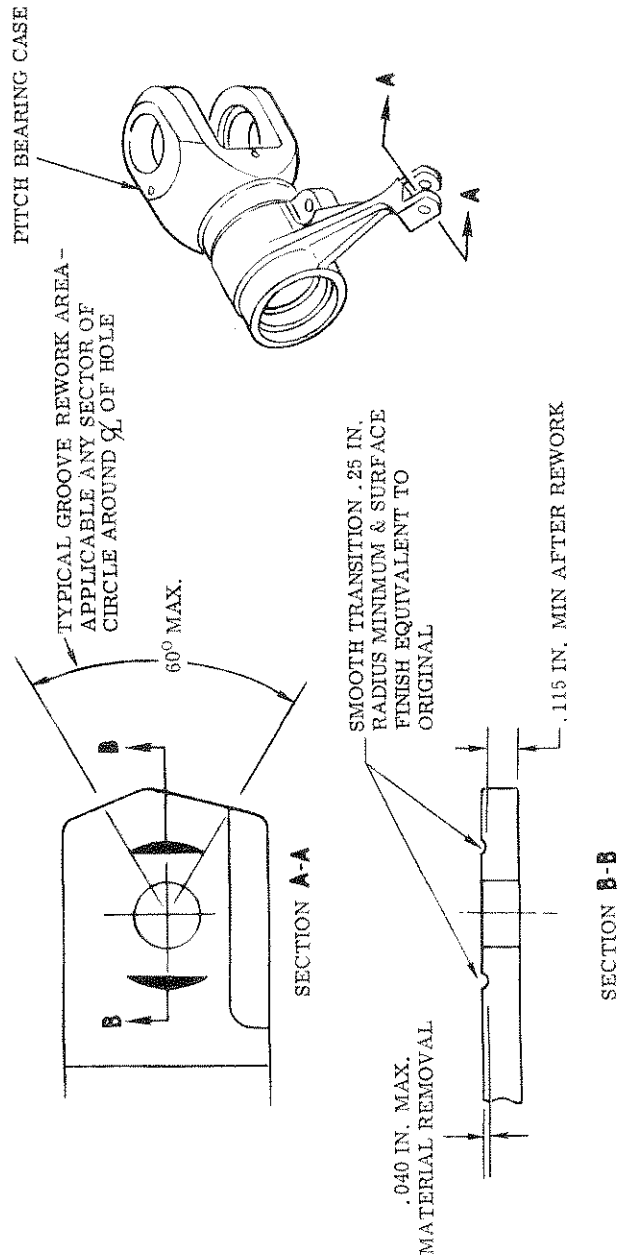

FIGURE 1. PITCH BEARING CASE-REWORK, PITCH LUGS

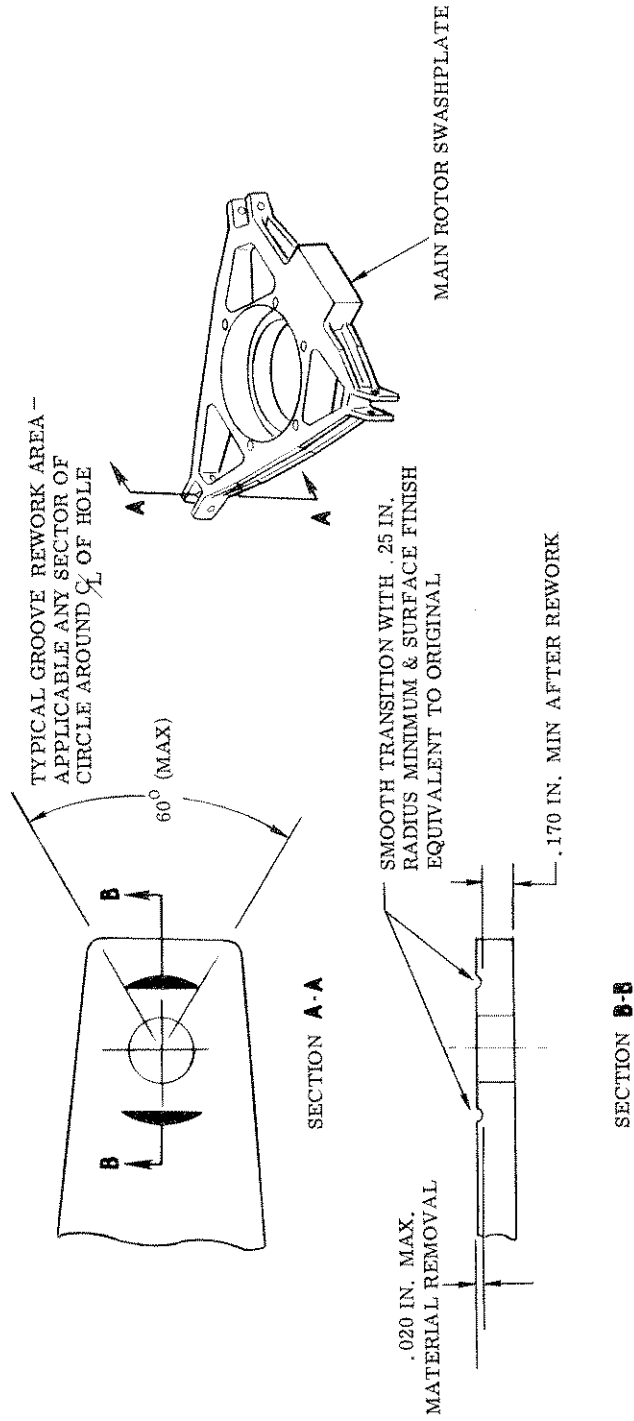

FIGURE 2. MAIN ROTOR SWASHPLATE-REWORK, PITCH LUGS

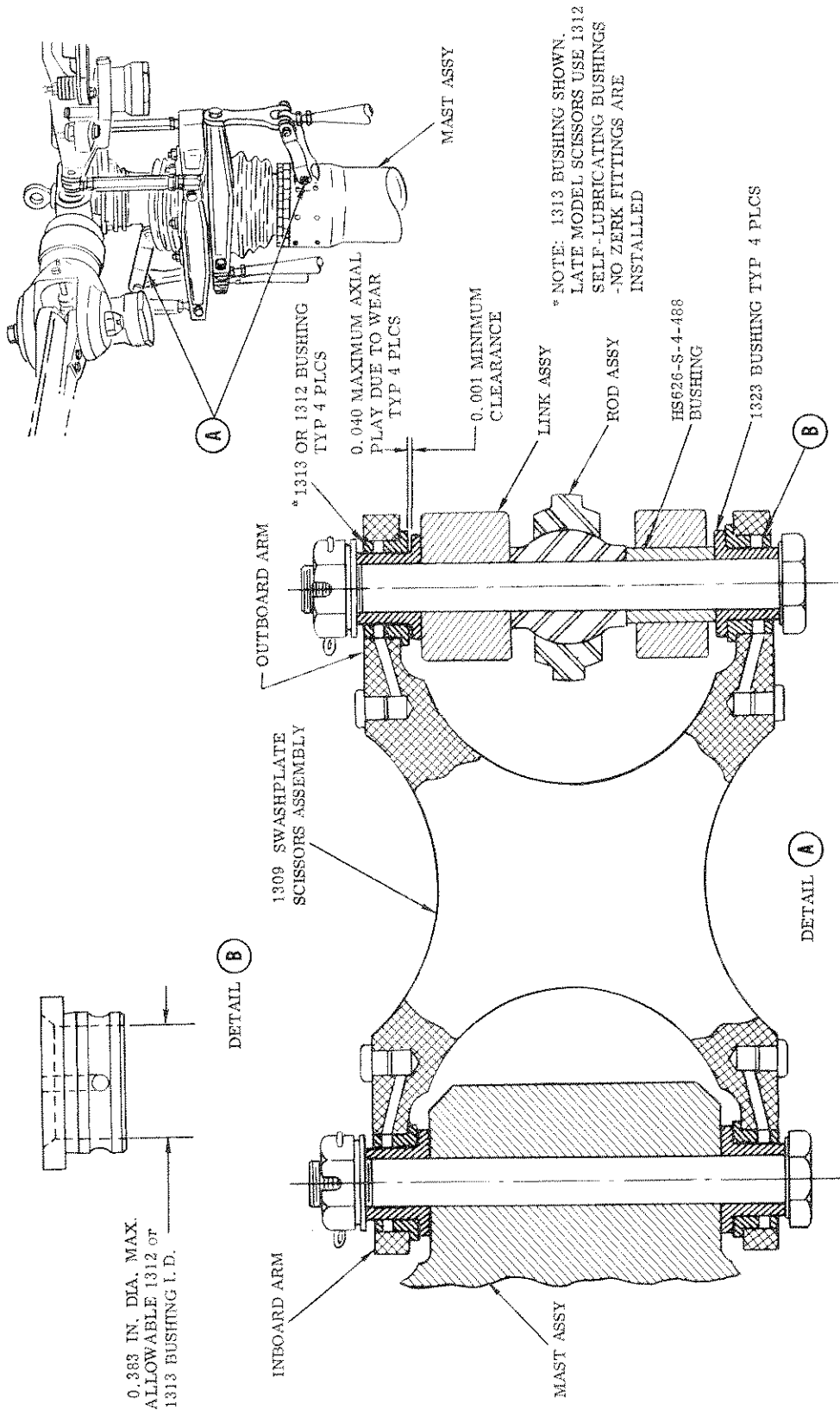

FIGURE 3. WEAR TOLERANCE-UPPER AND LOWER SWASHPLATE SCISSORS

