

TRANSMITTAL SHEET

Subject: ALERT SERVICE BULLETIN No. DB-041.1 - Tail Rotor Drive Shaft Splined Fittings – Perform a One-Time Inspection and Implement a Recurring Inspection for Wear.

This page transmits Revision 1 to Alert Service Bulletin (ASB) No. DB-041, dated February 13, 2012.

ASB No. DB-041.1 supersedes ASB No. DB-041, dated February 13, 2012.

Revision Instructions:

Operators who have already complied with ASB No. DB-041, dated February 13, 2012, must review effectivity to determine whether any further action is required.

Operators who have not complied with ASB No. DB-041, dated February 13, 2012 must comply with Revision 1 in its entirety.

The text changed by this revision is indicated by a vertical line in the outer margin of the page.

Revision Feature:

PLANNING INFORMATION

Revised Effectivity to more clearly define those helicopters which require inspection.

Revised Compliance to be within 100 flight hours or 60 days from the original release date of this ASB.

ACCOMPLISHMENT INSTRUCTIONS

Removed reference to Anderol 786 grease from Consumable Materials table and procedure.

Removed instruction to proceed to step B.7. in step 3.B.(4).

Changed NOTE on page 4.

Revised record of compliance instructions.

269D ALERT SERVICE BULLETIN

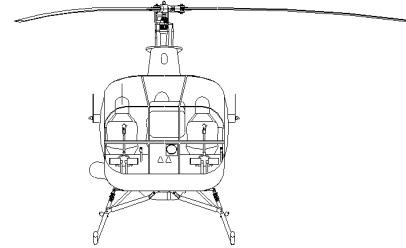

WARNING: THIS DOCUMENT, OR AN EMBODIMENT OF IT IN ANY MEDIA, DISCLOSES INFORMATION WHICH IS PROPRIETARY, IS THE PROPERTY OF SIKORSKY AIRCRAFT CORPORATION AND/OR ITS SUBSIDIARIES, IS AN UNPUBLISHED WORK PROTECTED UNDER APPLICABLE COPYRIGHT LAWS, AND IS DELIVERED ON THE EXPRESS CONDITION THAT IT IS NOT TO BE USED, DISCLOSED, REPRODUCED, IN WHOLE OR IN PART (INCLUDING REPRODUCTION AS A DERIVATIVE WORK), OR USED FOR MANUFACTURE FOR ANYONE OTHER THAN SIKORSKY AIRCRAFT CORPORATION AND/OR ITS SUBSIDIARIES WITHOUT ITS WRITTEN CONSENT, AND THAT NO RIGHT IS GRANTED TO DISCLOSE OR SO USE ANY INFORMATION CONTAINED HEREIN. ALL RIGHTS RESERVED. ANY ACT IN VIOLATION OF APPLICABLE LAW MAY RESULT IN CIVIL AND CRIMINAL PENALTIES.

EXPORT WARNING: THESE COMMODITIES, TECHNICAL DATA OR SOFTWARE ARE SUBJECT TO THE EXPORT CONTROL OF EITHER THE INTERNATIONAL TRAFFIC IN ARMS REGULATIONS (ITAR) OR THE EXPORT ADMINISTRATION REGULATIONS (EAR) AND CANNOT BE EXPORTED WITHOUT THE AUTHORIZATION OF EITHER THE DEPARTMENT OF STATE OR THE DEPARTMENT OF COMMERCE PRIOR TO EXPORT. EXPORT INCLUDES DISCLOSURE AND OR ACCESS TO COMMODITIES, TECHNICAL DATA OR SOFTWARE BY FOREIGN NATIONALS WHETHER LOCATED IN THE UNITED STATES OR ABROAD. THIS REQUIREMENT APPLIES EQUALLY TO FOREIGN NATIONAL EMPLOYEES OF U.S. COMPANIES AND THEIR FOREIGN SUBSIDIARIES.

DB-041.1

February 13/12

Revision 1 ▪ February 24/12

SUBJECT: DRIVE TRAIN - Tail Rotor Drive Shaft Splined Fittings – Perform a One-Time Inspection and Implement a Recurring Inspection for Wear

Section 1. PLANNING INFORMATION

- A. Effectivity All Schweizer model 269D helicopters.
- B. Purpose To perform a one-time inspection of tail rotor drive shaft splines for wear and to implement a recurring visual inspection of the tail rotor drive shaft splines.
- C. Description The tail rotor drive shaft splines are cleaned, inspected and lubricated. Splined components that exceed wear limits are removed from service and returned to Sikorsky Aircraft Corporation.

Excessive spline wear in the forward and aft tail rotor drive shaft splined fittings can lead to decoupling of the tail rotor drive shaft. A one-time inspection is required to check for excessive spline wear and to assure the drive shaft is properly lubricated. Follow-on 100 hour periodic inspections of these components are required in accordance with HMI CSP-D-2 and CSP-D-9 Appendix B, Table B-2.

The implementation of the recurring inspection shall be accomplished subsequent to the one-time inspection.

- D. Compliance Compliance is essential. The one-time inspection outlined herein shall be accomplished within 100 flight hours or 60 days from the original release date of this Alert Service Bulletin (ASB), whichever occurs first.
- E. Approval Inspection Item.

ONE-TIME
INSPECTION

IMPLEMENT
RECURRING
INSPECTION

DRIVE TRAIN

Section 1. PLANNING INFORMATION (Continued)

F. Manpower (Estimated)

<u>Task</u>	<u>No. of Men</u>	<u>No. of Hours</u>	<u>Man-Hours*</u>
Remove tail rotor drive shaft	2	.25	.50
Clean/inspect spline cavities	1	.50	.50
Lubricate spline cavities	1	.25	.25
Install tail rotor drive shaft	2	.30	<u>.60</u>
Total Man-Hours			1.85

*Estimate does not include time required to prepare helicopter or return it to flight status.

G. Material

None.

H. Tooling

(1) Lubrication Tool (locally fabricated)

I. Weight and Balance

Not affected.

J. Electrical Load Data

Not affected.

K. Software Load Data

Not applicable.

L. References

(1) 269D Basic HMI CSP-D-2.

(2) 269D Configuration A Basic HMI CSP-D-9.

M. Publications Affected

None.

N. Attachment

None.

Section 2. MATERIAL INFORMATION

A. Basis for Material Data

Per helicopter.

B. Bill of Material

None.

C. Consumable Material



OBSERVE ALL CAUTIONS AND WARNINGS ON CONTAINERS WHEN USING CONSUMABLES. WHEN APPLICABLE, WEAR NECESSARY PROTECTIVE GEAR DURING HANDLING AND USE. IF A CONSUMABLE IS FLAMMABLE OR EXPLOSIVE, MAKE CERTAIN CONSUMABLE AND ITS VAPORS ARE KEPT AWAY FROM HEAT, SPARK AND FLAME. MAKE CERTAIN FIREFIGHTING EQUIPMENT IS READILY AVAILABLE PRIOR TO USE. FOR ADDITIONAL INFORMATION ON TOXICITY, FLASHPOINT AND FLAMMABILITY OF CHEMICALS, CONSULT YOUR MEDICAL PEOPLE OR THE MANUFACTURER OF THE CONSUMABLE.

<u>Qty</u>	<u>Nomenclature</u>	<u>Part No.</u>	<u>Source</u>
As Req'd	Solvent	Stoddard Solvent, MIL-PRF-680, Type I, or equivalent (Alternate) Varsol, MIL-PRF-680, Type II, or equivalent	(1)
As Req'd	Grease	Syn-Tech NS-3913-G1, or equivalent	(2)
As Req'd	Polypropylene Plastic Sheet, 0.125-inch thick	Commercial grade or equivalent	(3)
As Req'd	PVC Pipe, 0.75-inch diameter	Commercial grade or equivalent	(3)
As Req'd	PVC Adhesive	Commercial grade or equivalent	(3)

(1) Stoddard solvent is available from www.sciencestuff.com.
 Varsol is available from www.exxonmobilechemical.com.

(2) Syntech is available from www.syn-techlube.com.

(3) Procure from local supply.

Section 3. ACCOMPLISHMENT INSTRUCTIONS

- A. Prepare helicopter for inspection:
 - (1) Turn off all helicopter electrical power.
 - (2) Remove tail rotor drive shaft from helicopter. Reference Applicable Basic HMI, Section 10.
 - (3) Using cleaning solvent, remove all grease from spline cavities of tail rotor drive shaft forward and aft end fittings and main rotor transmission pinion splined drive sleeve and driven spline adapter of tail rotor transmission. Blow dry with clean, compressed air.
- B. Perform tail rotor drive shaft splined fitting inspection as follows:

- (1) Visually inspect internal splines of forward and aft drive shaft fittings for excessive wear, galling, spalling, chipping, distortion, corrosion, heat discoloration or any defect that indicates inadequate spline engagement or lack of lubricant.
 - (a) Measure internal splines of fittings for excessive wear. Reference Applicable Basic HMI, Section 10.

NOTE: The main transmission pinion drive spline sleeve and the tail rotor transmission driven spline have identical external spline dimensions. The overall pin dimension inspection applies to both.

- (2) Visually inspect external splines of drive sleeve on main rotor transmission pinion and external splines of driven spline on tail rotor transmission input shaft for excessive wear, galling, spalling, chipping, distortion, corrosion, heat discoloration, or any defect that indicates inadequate spline engagement or lack of lubricant.
 - (a) Measure for excessive wear over two 0.1200 inch diameter gage pins placed 180° apart in external splines. Reference Applicable Basic HMI, Section 10.
- (3) If tail rotor drive shaft is equipped with grease fittings, inspect grease fittings for security, presence of check balls inside fittings, and for proper operation and seating of check balls. Replace any grease fittings that are loose, are missing check balls, or are suspected of improper operation.
- (4) If wear is found in splines of drive shaft fittings, splined drive sleeve or splined adapter which meets serviceable limits, copy and fill out the Customer Reply Form and mail to address shown on form.

NOTE: Contact HSI for return and evaluation.

- (5) Remove from service any components that exceed wear limits and send to Helicopter Support Inc. (HSI). Fill out Component Return Form and place in shipping container and ship components to address shown on form.

Section 3. ACCOMPLISHMENT INSTRUCTIONS (Continued)

- (6) Service drive shaft fittings as follows:
 - (a) Service drive shafts that are not equipped with grease fittings as follows:
 - 1. Fabricate and assemble Lubrication Tool (Figure 1 Sheet 1 and Sheet 2).
 - 2. Apply grease (Syn-Tech NS-3913-G1 grease or equivalent) to drive shaft fittings (Figure 1, Sheet 2).
 - 3. Adjust grease volume in fittings by inserting tool until legs of Lubrication Tool plates bottom against safety wire flanges on exterior of splined fittings (Figure 1, Sheet 2).
 - 4. Rotate tool a minimum of 180°. Verify grease coverage and depth as required in HMI. Reference Applicable Basic HMI, Section 10.
 - (b) Service drive shafts equipped with grease fittings with grease (Syn-Tech NS-3913-G1 grease or equivalent). Grease aft fitting first and avoid aft preloading by alternately greasing fittings at both ends. Reference Applicable Basic HMI, Section 10.

(7) Install tail rotor drive shaft in helicopter. Reference Applicable Basic HMI, Section 10.

B. Implement recurring tail rotor drive shaft inspection as follows:

- (1) Review and comply with Applicable Basic HMI Appendix B, Table B-2.

C. Record of compliance:

- (1) Make helicopter logbook entries to show compliance with this ASB as follows:
 - (a) Make helicopter level logbook entry on form SA7343-15.
 - (b) When ASB modifies a component that can be removed from this helicopter:
 - 1. Make component log card entries on forms SA7343-22 & SA7343-21 as applicable.
- (2) Upon compliance with this ASB, complete attached ALERT SERVICE BULLETIN COMPLIANCE RECORD CARD and return it to Sikorsky Aircraft Corporation.

Section 3. ACCOMPLISHMENT INSTRUCTIONS (Continued)

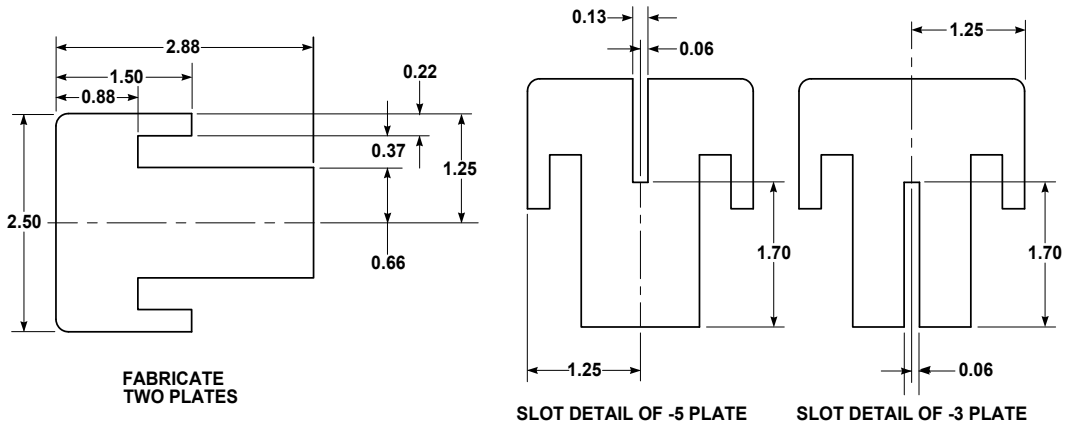

LUBRICATION TOOL DETAILS FOR FORWARD SPLINED FITTING

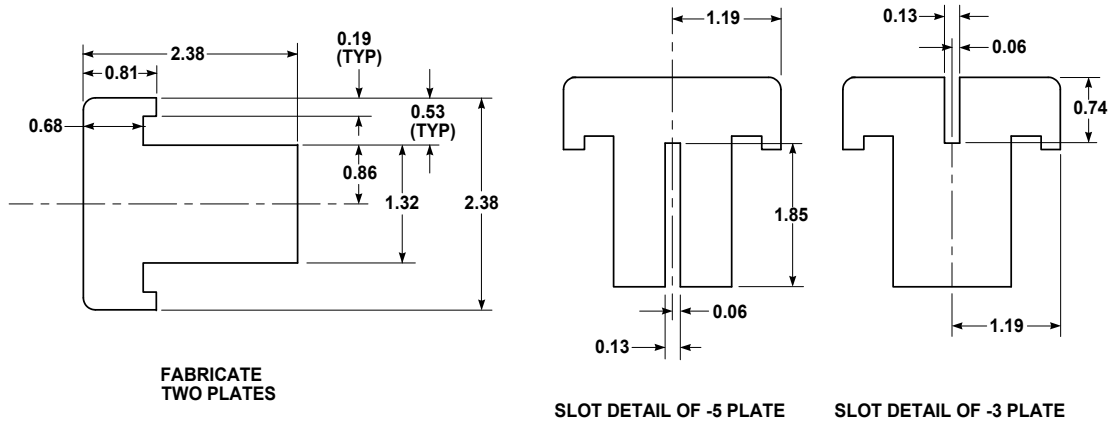

LUBRICATION TOOL DETAILS FOR AFT SPLINED FITTING

NOTES

1. SUGGESTED MATERIAL IS 1/8 INCH THICK POLYPROPYLENE PLASTIC SHEET AND 3/4 INCH PVC PIPE. ANY SUITABLE MATERIAL MAY BE USED.
2. FABRICATE - 1 PVC PIPE HANDLE AS SHOWN IN SHEET 2 WITH SLOTS 90° APART. SLOT WIDTHS ARE TO MATCH MATERIAL THICKNESS.
3. ASSEMBLE PARTS AS SHOWN IN SHEET 2 AND BOND ASSEMBLY TOGETHER USING APPROPRIATE ADHESIVE FOR PVC PIPE.

C1B-022_4
SA

LUBRICATION TOOL – FABRICATION OF DETAIL PARTS
FIGURE 1 (SHEET 1 OF 2)

Section 3. ACCOMPLISHMENT INSTRUCTIONS (Continued)

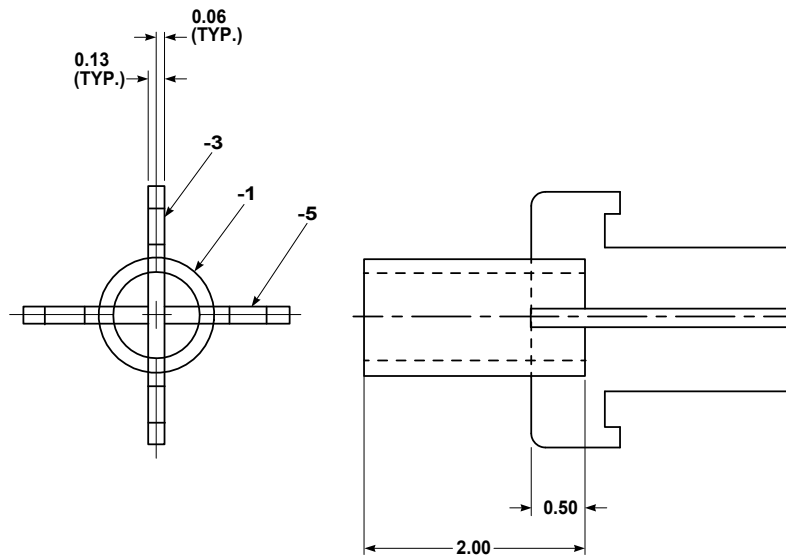

**ASSEMBLY OF LUBRICATION TOOL
FOR AFT SPLINED FITTING SHOWN**

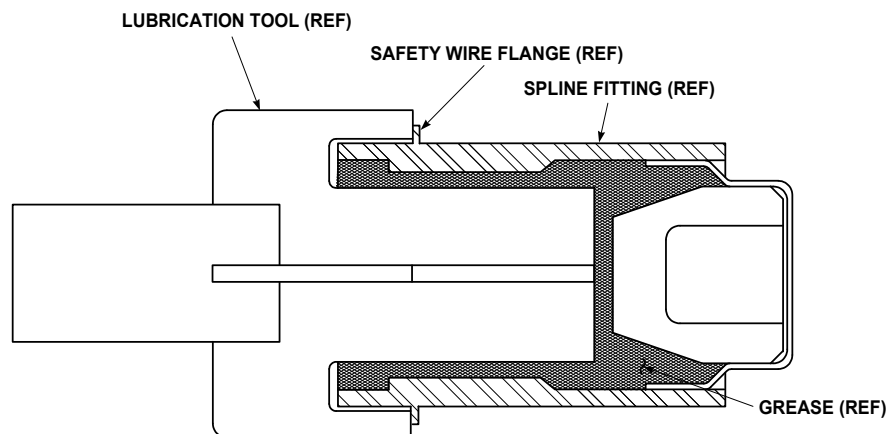

LUBRICATION TOOL – ASSEMBLY AND USE
FIGURE 1 (SHEET 2 OF 2)
COMPONENT RETURN FORM

Customer Name: _____ Helicopter Model: _____

Customer Address: _____ Helicopter Serial N^o: _____

_____ Component Time: _____

Ship To: Helicopter Support Inc.
124 Quarry Rd.
PO Box 11068
Trumbull, Connecticut, 06611 USA
Attn: Customer Service
Fax: (203) 416-4291 Telephone: (203) 416-4000
HSI Website: www.HSIUS.com

COMPONENT RETURN FORM

Customer Name: _____ Helicopter Model: _____

Customer Address: _____ Helicopter Serial N^o: _____

_____ Component Time: _____

Ship To: Helicopter Support Inc.
124 Quarry Rd.
PO Box 11068
Trumbull, Connecticut, 06611 USA
Attn: Customer Service
Fax: (203) 416-4291 Telephone: (203) 416-4000
HSI Website: www.HSIUS.com

DRIVE TRAIN

IMPLEMENT
RECURRING
INSPECTION

ONE-TIME
INSPECTION

CUSTOMER REPLY FORM

Customer Name: _____ Helicopter Model: _____

Customer Address: _____ Helicopter Serial N^o: _____

COMPONENT:

Drive Shaft FWD Splined Fitting:

Wear: _____ Total Time: _____

Drive Shaft AFT Splined Fitting:

Wear: _____ Total Time: _____

Main Trans. Pinion Drive Splined Sleeve:

Dimensions: _____ Total Time: _____

Tail Gearbox Driven Spline Adapter:

Dimensions: _____ Total Time: _____

Mail To: Helicopter Support Inc.
124 Quarry Rd.
PO Box 11068
Trumbull, Connecticut, 06611 USA
Attn: Customer Service
Fax: (203) 416-4291 Telephone: (203) 416-4000
HSI Website: www.HSIUS.com

ONE-TIME
INSPECTION

IMPLEMENT
RECURRING
INSPECTION

DRIVE TRAIN

(Fold over and tape closed)

SIKORSKY AIRCRAFT CORPORATION

FACSIMILE NUMBER (860) 998-7565

EMAIL ADDRESS: GPSIKSASProductSafet@utc.com

ATTENTION: SAS PRODUCT SAFETY MANAGER
SIKORSKY AEROSPACE SERVICES



IMPORTANT NOTICE

Upon **COMPLIANCE** with the attached ASB, Sikorsky requests your cooperation in completing and returning this **ENTIRE PAGE** by MAIL, FAX, or scan & EMAIL.

If you have internet access, you may go to www.sikorsky.com to record your compliance.

Please fill in the requested information at the bottom of the page, so we may maintain proper records documenting the configuration of your aircraft. This information is useful when determining configuration and effectivity of issues affecting fielded aircraft.

This request is in keeping with our policy to assure that our customers receive the latest information applicable for the maintenance of your aircraft. Thank you.

ALERT SERVICE BULLETIN: ASB No. DB-041.1 **Compliance Record Card**

TITLE: DRIVE TRAIN – Tail Rotor Drive Shaft Splined Fittings – Perform a One-Time
Inspection and Implement a Recurring Inspection for Wear

OWNER/OPERATOR: _____

SUBMITTED BY: _____ **DATE:** _____

FOLLOWING SERIAL NUMBERS ARE NOT AFFECTED BY THIS ASB

ASB HAS BEEN COMPLIED WITH ON THE FOLLOWING SERIAL NUMBERS

(Fold Up to Arrows)



No Postage
Necessary

BUSINESS REPLY MAIL
FIRST-CLASS MAIL PERMIT NO. 432 BRIDGEPORT CT

POSTAGE WILL BE PAID BY ADDRESSEE

SIKORSKY AIRCRAFT CORPORATION
P.O. BOX 9729
6900 MAIN STREET
STRATFORD, CONNECTICUT 06615-9129 U.S.A.
MAILSTOP: **S328A**
ATTENTION: SAS PRODUCT SAFETY MANAGER
SIKORSKY AEROSPACE SERVICES

**Please complete the form on the reverse side and FAX to
FACSIMILE NUMBER (860) 998-7565**

Or scan and email to:

**EMAIL ADDRESS: GPSIKSASProductSafet@utc.com
or fold and return ENTIRE form to Sikorsky Aircraft Corporation**